

REVIEW

Open Access



Evolution of 3D weaving and 3D woven fabric structures

Yasith Sanura Perera^{1*} , Rajapaksha Mudiyansele Himel Widooshaka Muwanwella¹, Philip Roshan Fernando¹, Sandun Keerthichandra Fernando² and Thantirige Sanath Siroshana Jayawardana³

*Correspondence:

yasiths@uom.lk

¹ Lecturer, Department of Textile and Clothing Technology, Faculty of Engineering, University of Moratuwa, Moratuwa, Sri Lanka

Full list of author information is available at the end of the article

Abstract

3D fabric preforms are used as reinforcements in composite applications. 3D woven preforms have a huge demand in ballistic applications, aircraft industry, automobiles and structural reinforcements. A variety of 3D woven fabric reinforced composites and two dimensional woven fabric reinforced laminates can be found in the literature. However, the majority of the said products lack in delamination resistance and possess poor out-of-plane mechanical characteristics, due to the absence or insufficiency of through-thickness reinforcement. 3D fully interlaced preform weaving introduces a method of producing fully interlaced 3D woven fabric structures with through-thickness reinforcement, which enhances the delamination resistance as well as out-of-plane mechanical characteristics. 3D woven fabric preforms made from 3D fully interlaced preform weaving, using high-performance fiber yarns such as Dyneema, Carbon, Kevlar and Zylon, have exceptional mechanical properties with light-weight characteristics, which make them suitable candidates for high-end technical composite applications. In this work, a brief introduction is given to the history of weaving followed by an introduction to 3D woven fabrics. In the existing literature, an emphasis is given to the 3D fully interlaced preform weaving process, distinguishing it from other 3D woven fabric manufacturing methods. Subsequently, a comprehensive review is made on the existing literature on 3D fully interlaced preform weaving devices, such as primary and secondary mechanisms as well as modelling of 3D woven fabric structures produced by 3D fully interlaced preform weaving. Finally, the authors attempted to discuss the existing research gaps with potential directions for future research.

Keywords: 3D weaving, Preforms, Composites, 3D fabric, Technical textiles

Introduction

History of weaving

Weaving is an evolving technology used for producing fabrics through the interlacement of two perpendicular sets of yarns. It has been in use since the Neolithic/Endolithic period (Adovasio et al. 2014). Traces of woven fabrics had been found in archaeological sites around the world. According to the archaeologist Kramrisch, the knowledge and mastery of the skill have long been a matter of intellectual pride (Kramrisch 1968). In the early stages, the primary objective of woven fabrics was to give protection through clothing and shelter. However, with a growing population and ever-improving advanced

technologies, nowadays fabrics are mostly used for fashion and performance, thus enhancing the standard of living of human beings.

At the inception, a set of warp yarns was hanged from a branch of a tree and the wefts were inserted manually. This can be stated as the first appearance of a 'loom'. The term 'loom' in this context, is defined more generally as any frame or contrivance for holding the warp threads parallel to each other, to permit the interlacing of the weft at right angles to form a web (Broudy 1993). With the inspiration from this, the 'vertical loom' had been developed and eventually, the 'horizontal loom' came into existence which is the predecessor of the modern weaving loom. But the transition of the handloom into the modern loom is widespread throughout the history and underwent many phases of evolution as studied by Broudy (1993). However, all of these technologies were dedicated to only two dimensional (2D) woven fabrics.

Modern days, the Computer-Aided Design (CAD) and simulation platforms, have opened up new avenues for traditional weaving (Vassiliadis et al. 2011). These include but not limited to, smart integrations of electronics, reinforcements, medical applications, 3D contour weaving in 2D platforms and multi-axial weaving. Even though the concept of 3D fabrics is treated as a new concept, it has been in existence for a long period. Evidence of 3D weaving can be seen in pre-historic ages as the pre-historic humans had used weaving to produce baskets and other utensils for their day-to-day needs. The earliest evidence of basketry comes from the Guitarrero Cave in Peru, during the period 8600–8000 B.C. (Broudy 1993). However, during these early stages manual processes were used and the application of a machine in 3D weaving had first appeared in the form of the 'tablet loom'. Since this development, technologies focused on the manufacturing of 3D woven fabrics have been developed and used for the reinforcement of concrete structures, 3D woven vehicle components, woven sacks and many other applications.

Not only the development of the machines and the technology but the simple application possibilities, the ability to produce very complex parts without the requirement of assembling and very low production costs have fueled the growth of 3D woven fabrics (Tong et al. 2002). Another major factor that has contributed to the growth of the 3D weaving technology was the introduction of new high-performance fibres. The natural fibres have a high aesthetic appeal in fashion fabrics. Until 100 years ago, these fibres were also used in engineering applications, which were called technical or industrial textiles. With the introduction of man-made fibres in the first half of the twentieth century, new textile fibres were available for fashion fabrics, with excellent performance characteristics. For example, the reinforcements in automobile tires moved from cotton cords in 1900, to a sequence of improved rayons from 1935 to 1955, and then to nylon, polyester and steel, which dominate the market now. A similar replacement of natural and regenerated fibres by synthetic fibres occurred in many technical textiles (Hearle 2001). In the scope of 3D woven fabrics, the performance of fibres is very critical for the production and also the integrity of the produced structures. The fibres should possess high strength and rigidity. In 3D woven fabrics, high crimp can be observed due to the interlacing of yarns in different dimensions, and therefore, the chance for a yarn breakage is high and these breakages should be prevented by the high yarn strength (Tong et al.

2002). The rigidity of the yarn is important as the 3D woven fabric has to maintain its integrity and the final shape.

Early developments of the fibres were mainly focused on the tactile comfort properties of fabrics, as the main application of the fibres was to manufacture textiles for apparel applications. With the developments in the technical textiles sector, usage of textiles in high-end technical applications has increased. Consequently, the performance characteristics became much more important than the tactile comfort properties of the textiles. As the fibres were developed with good performance and lightweight characteristics, using these fibres for the development of 3D woven structures has become feasible (Tong et al. 2002).

Woven reinforcements are mostly produced with high-performance fiber yarns such as glass, carbon and aramid (Ogin & Potluri 2016). In two dimensional (2D) woven fabric reinforcements, two orthogonal sets of yarns are interlaced together and in some cases, multiple layers of such fabrics are present in the cross-section of the composite. Therefore, the stability of the composite is observed along two axes or a maximum of three axes only, and this was not sufficient for most of the applications. Consequently, laying of the yarns in different axes and the production of multi-axis fabrics have been experimented (Curiskis et al. 1997).

The first approach was to increase the stability of the third dimension of a two dimensional (2D) woven fabric produced on a regular weaving machine. This was achieved by the addition of a binding yarn to bind off the wefts in between warp yarns. This had been carried out using a set of needles passing in between warp yarns, threaded with the binding yarns form a different warp beam. This technique is known as the lappet weaving technique (Curiskis et al. 1997). However, this technique provided stability in two dimensions only and the torsional and bending rigidity of the fabric was not sufficient. Therefore, another approach had been developed, which is known as tri-axial weaving. In this technique, the warp sheet is moved orthogonally to its arrangement and the wefts are inserted. This created a stable structure for two dimensional (2D) woven structures, and later on, this technique had been combined with the lappet weaving technique and the concept of multi-axial weaving was introduced. In the multi-axial weaving technique, the fabrics produced possessed good stability as well as sufficient thickness and strength to bear the loads and they were ideal for simple planar composites. But when it comes to complex-shaped composites, these fabrics were not suitable as they cannot be molded into different shapes due to the high planar stability. To overcome this issue, 3D woven fabric structures for composites were developed.

Introduction to 3D woven fabrics

A slight distinction can be made between 2D and 3D fibrous assemblies, based on the dimensions of the assembly. Textile structures with a negligible thickness compared to the length and width can be loosely defined as two dimensional (2D) fabrics (Umair et al. 2015). Two dimensional (2D) biaxial woven structures have two sets of yarns, warp and weft, intersecting and interlacing at right angles with one another (Hu 2008). On the other hand, three dimensional (3D) fabrics are textile structures with a substantial thickness. 3D woven fabric structures consist of three yarn components in three orthogonal directions x , y and z , where the z -yarn reinforces the through-thickness direction of the

fabric (Yang et al. 2004). A further distinction among three fabric classes, namely 2D, 2.5D and 3D fabrics, is described by Khokar (1996). According to this distinction, a 2D fabric has its constituent yarns disposed of in a single plane, a 2.5D fabric such as the terry pile fabric, has its constituent yarns disposed of in a two-mutually-perpendicular-planes relationship, while a 3D fabric has its constituent yarns disposed of in a three-mutually-perpendicular-planes relationship. However, it should be noted that a 3D fabric need not necessarily comprise three sets of yarns, instead may comprise two or more than three sets of yarns (Khokar 2001).

Two dimensional (2D) woven fabrics are widely used in ballistic applications, to protect against projectiles, hand grenades, stabbing, etc. The high in-plane properties of plain, basket and twill weave make them more suitable fabric structures for soft vest applications, while satin weaves are more suitable for rigid composite armor applications (Bilisik 2017). Multi-stitched fabrics can also be produced by stitching two dimensional (2D) woven fabrics in the fabric out-of-plane direction. Polymer laminates reinforced with 2D fabric structures have long been used in maritime crafts, aircraft, automobiles and buildings and bridges. However, the manual lay-up of fabric plies leads to high labor requirement, resulting in high manufacturing costs. Furthermore, their inferior impact resistance and low through-thickness mechanical properties compared to traditional aerospace and automotive materials restrict the use of 2D laminates in certain aircraft and automobile applications. Another problem related to 2D laminates is the low resistance to delamination cracking under impact loading, due to poor inter-laminar fracture toughness (Mouritz et al. 1999). In aeronautics, delamination in laminated woven composites occurs under high vibrations leading to a failure (Nawab et al. 2012). To overcome the poor delamination resistance and improve impact damage tolerance, composites can be reinforced in the through-thickness direction, using fibrous yarns, rods or pins, which is collectively known as z-reinforcement. This can be achieved through 3D weaving, stitching and z-pinning (Mouritz 2008). Stitching and z-pinning improve impact damage tolerance, but at the expense of in-plane properties (Umair et al. 2019). The z-yarns in the 3D woven fabric reinforced composites, provide better impact energy absorption and delamination resistance (Zhang et al. 2013).

3D woven fabrics can be produced with complex near-net-shape geometries, which reduces the cost by reducing material wastage, the need for machining and joining and the amount of material handled during lay-up. The through-thickness properties of 3D woven fabrics can be tailored to suit a particular application. They have high delamination resistance, ballistic damage resistance and impact damage tolerance (Mouritz et al. 1999).

3D woven fabric forming methods

A specific classification described by Bilisik (1991), categorized 3D woven preforms based on the type of interlacement and yarn orientation. In another study, 3D woven fabrics were categorized based on the type of weaving and the fabric structure (Behera & Mishra 2008). Based on the type of weaving process, 3D woven fabrics were classified into three categories; 2D weaving—3D fabrics, 3D weaving—3D fabrics and noobing. Based on the fabric structure, they were classified into four categories; 3D solid, 3D

hollow, 3D shell and 3D nodal. Khokar (1996) clearly distinguished between three methods of manufacturing 3D fabrics; 2D weaving, 3D weaving and noobing.

Using the conventional 2D weaving process, three classes of fabrics, namely 2D, 2.5D and 3D fabrics can be produced (Khokar 1996). The 3D fabrics can be produced primarily in two different ways using the conventional 2D weaving process; which are called 'multi-layer weaving' and 'noobing'. A clear distinction between these two methods is provided by Khokar (1996) and Khokar (2002a). Khokar claimed that noobing does not comply with the principles of 2D weaving, due to the absence of the shedding mechanism, which is a primary mechanism of 2D weaving.

The 3D multi-layer interlock woven structures produced using the conventional 2D weaving process can be categorized as orthogonal interlock and angle interlock structures (Umair et al. 2018). These fabric classes may further be categorized as layer-to-layer interlock and through-thickness interlock, based on the crossing pattern of yarns. Umair et al. (2018) produced three different types of 3D orthogonal layer-to-layer interlock woven composite preforms (i.e. warp, weft and bi-directional) and evaluated their effect on the mechanical properties. Based on the results, the authors recommended bi-directional interlock composites for transversal direction applications, due to the improved mechanical performance compared to warp and weft interlock composites. Ali et al. (2018) developed 3D woven T-shaped preforms using a narrow multi-layer weaving machine and observed significant improvements in peel-off strength and impact strength in composites reinforced with the developed preforms. Kashif et al. (2019) investigated the effect of different interlocking patterns (i.e. warp interlock, weft interlock and hybrid) on the mechanical properties of layer-to-layer and through-thickness fabric preforms made of jute yarns.

Multi-axis 3D woven fabrics can be produced by incorporating bias yarns into the structure. Bilisik (2010b) introduced two 3D multi-axis weaving methods called tubewriter weaving and tube-carrier weaving. The incorporation of bias yarns into the structure improves the delamination resistance as well as in-plane properties (Bilisik 2012). However, the bias yarns cause a reduction in bending properties in comparison to 3D orthogonal woven structures (Bilisik et al. 2013). Bilisik (2012) provided a comprehensive review of different classes of multi-axis 3D woven fabrics and their manufacturing methods.

Khokar (1996) further established a clear-cut distinction between the 2D weaving method of forming 3D woven fabrics and the 3D fully interlaced preform weaving method. Since the focus of this review is on the 3D fully interlaced preform weaving process, it is worthwhile for the reader to understand this distinction between the two processes.

In the multi-layer weaving process described above, the shedding mechanism forms a shed in the fabric-width direction, which allows the interlacement of the multi-layer warp with the weft. However, if another set of yarns are to be laid across the fabric-thickness direction, the conventional 2D weaving process cannot enable the interlacement of this set of yarns with the other two sets of yarns, as the conventional 2D weaving process cannot form a shed in the fabric-thickness direction. Therefore, the conventional 2D weaving process is not capable of producing a 'fully interlaced 3D woven fabric', in which all the three orthogonal sets of yarns are interlaced with each other (Khokar 1996).

A process developed by Fukuta et al. (1982), enabled the production of a fully interlaced 3D fabric, by interlacing three orthogonal sets of yarns with each other and complies with the principles of weaving. The process can carry out the shedding mechanism across both fabric-width and fabric-thickness directions, which allows the multi-layer warp to be interlaced with the horizontal and vertical weft yarns. This shedding mechanism is termed 'dual-directional shedding'. Fukuta et al. (1982) provided the earliest evidence for a 3D fully interlaced preform weaving device. Khokar (1996) referred to this process as 'true 3D weaving', but the term '3D fully interlaced preform weaving' will be used consistently throughout this paper, to refer to this process. Fabrics produced using such a 3D fully interlaced preform weaving process can be referred to as 3D woven 3D fabrics (Khokar 1996) and this term will be used consistently throughout this paper to describe such fabrics. Despite the ability of the conventional 2D weaving process to produce 3D fabric structures, it cannot be considered as a 3D fully interlaced preform weaving process, as it does not incorporate dual-directional shedding.

Analysis of the existing research on 3D fully interlaced preform weaving

Existing 3D fully interlaced preform weaving devices

With the development of the dual-directional shedding mechanism, it has become possible to interlace a multi-layer warp with a set of horizontal and vertical wefts, in the fabric-width and fabric-thickness directions, respectively. The resultant fabric has a fully interlaced 3D woven structure. Khokar (2001) set out three essential requirements that must be satisfied, to successfully carry out the 3D fully interlaced preform weaving process.

- i. A multi-layer warp disposed of in a grid-like arrangement.
- ii. A dual-directional shedding operation (to form column-wise and row-wise sheds).
- iii. Two orthogonal sets of weft yarns (horizontal and vertical sets of wefts).

Fukuta et al. (1982) disclosed the construction of an apparatus which is capable of producing a fully interlaced 3D woven structure, through what is previously established as the 3D fully interlaced preform weaving process. This process complies with the three essential requirements that must be satisfied, to carry out the 3D fully interlaced preform weaving process, as set out by Khokar (2001). The 3D fully interlaced preform weaving apparatus disclosed by Fukuta et al. (1982), is illustrated in Fig. 1.

The apparatus shown in Fig. 1 comprises two heald bars, which have a special heald eye arrangement and can reciprocate horizontally. These two heald bars are responsible for the shedding operation of the device, which forms two sets of sheds successively, one in the fabric-width direction and the other in the fabric-thickness direction. This enables the insertion of a set of wefts across each set of sheds to form a fully interlaced 3D woven fabric.

Fukuta et al. (1986) disclosed another apparatus that can be used to produce fully interlaced 3D woven structures, which is illustrated in Fig. 2. This device is similar in construction to the 3D fully interlaced preform weaving device disclosed by Fukuta

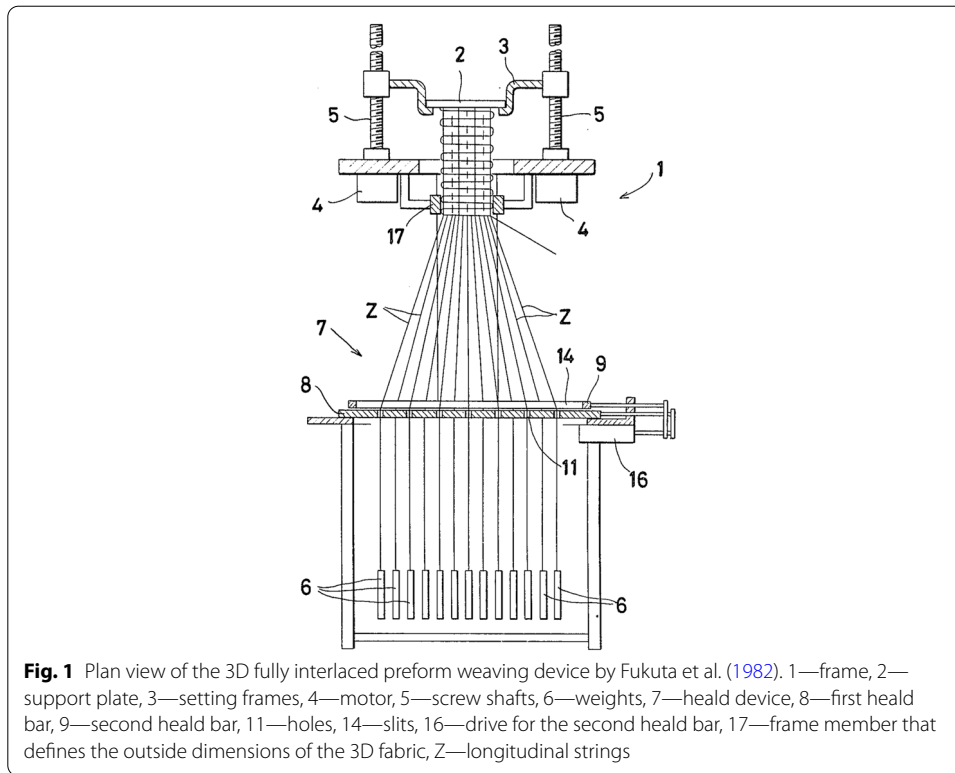

et al. (1982), but it does not employ a dual-directional shedding mechanism. The mechanisms involved in producing a fabric using this device are explained in detail by Fukuta et al. (1986). However, despite its ability to produce fully interlaced 3D woven fabrics, the process does not qualify as 3D fully interlaced preform weaving, as it does not employ a shedding mechanism, which is the foremost operation of weaving.

Khokar (2001) presented an experimental 3D fully interlaced preform weaving device, which incorporates a dual-directional shedding method called the linear-linear method, disclosed by Khokar (2002b). 400 warp ends can be accommodated in the grid-like warp sheet, arranged in twenty rows and twenty columns. Weft insertion is carried out using specially constructed shuttles. The shedding and weft insertion mechanisms are pneumatically controlled. Each heald frame of the device contains ten healds which allow the formation of twenty sheds simultaneously, in a given direction. Hence, twenty wefts can be inserted simultaneously in corresponding directions. Consequently, the device has a total of forty shuttles, twenty for each direction. Two pairs of shuttle banks are located for housing the shuttles, one for the vertical shuttles and the other for the horizontal shuttles. Each shuttle has a pair of boxes in the corresponding banks. A linear fabric take-up system with a profile holder is incorporated, which holds the leading ends of the warp yarns according to the profile of the cross-section of the fabric, to maintain the structure and the profile of the constructed fabric.

A similar device was presented by Khokar (2014), which employs the linear-linear method of dual-directional shedding. The multi-layer warp is disposed of in such a way, that the produced fabric has a ‘T’ shaped cross-section. A linear fabric take-up

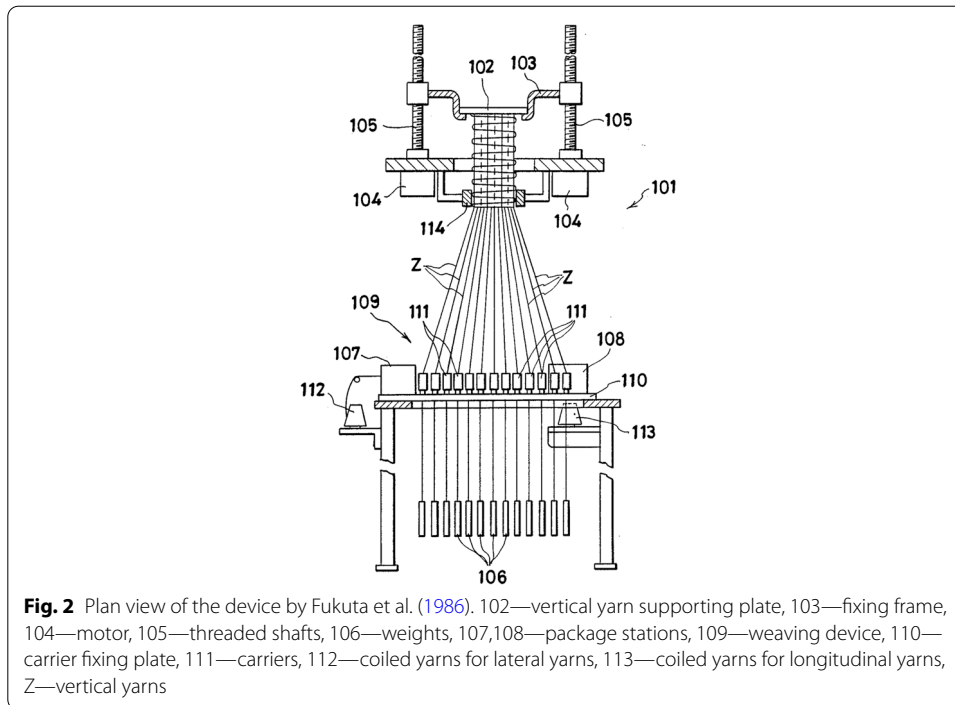

device with a ‘T’ shaped profile holder is incorporated and a creel that accommodates multiple warp spools is used to feed the warp yarns.

In another research, an experimental 3D weaving prototype had been developed which employs the linear–linear method of dual-directional shedding (Weerasinghe et al. 2017). The prototype is capable of accommodating a grid-like warp consisting of 100 warp ends arranged in 10 rows and 10 columns. The dual-directional shedding requires the two orthogonal sets of wefts to be inserted in two directions; horizontally and vertically, so that the wefts are inserted in both row-wise and column-wise sheds. However, in this system, both sets of wefts are inserted from one direction (i.e. horizontally), using rapiers. To accommodate this, the shedding, take-up and let-off mechanisms are rotated by 90°, for every weaving cycle, which allows the wefts to be inserted from one direction, in both column-wise and row-wise sheds. The sequence of operations of the prototype for producing a plain-weave fully interlaced 3D woven fabric was explained by Weerasinghe et al. (2017). This device employs a linear take-up system, similar to the one employed in the device developed by Khokar (2001). However, the take-up system in the device developed by Weerasinghe et al. (2017) rotates during the weaving process, whereas the take-up system of the device developed by Khokar (2001) is stationary. The let-off and take-up distances are maintained as required to regulate the warp tension and the warp crimp.

Various researches had been carried out on producing 3D woven fabric structures using circular weaving technology (Bilisik 1998, 2000, 2010a; Bilisik & Mohamed 2009). However, these techniques do not employ the dual-directional shedding mechanism and hence do not qualify as 3D fully interlaced preform weaving and the developed

structures do not possess a fully interlaced 3D woven structure. Bilisik et al. (2014) proposed a method which employs the dual-directional shedding in circular weaving, which enables the production of a fully interlaced circular 3D woven preform. Details of the experimental device were not disclosed by Bilisik et al. (2014), however, the device employs a set of warp or axial yarns which are arranged in a matrix of circular rows and radial columns, a dual-directional shedding mechanism which forms two sets of sheds in the radial and circumferential directions and two orthogonal sets of weft yarns inserted in the radial and circumferential directions. Hence, the device satisfies the requirements set out by Khokar (2001) to be qualified as a 3D fully interlaced preform weaving device.

Shedding mechanisms

Dual-directional shedding mechanism disclosed by Fukuta et al. (1982)

The apparatus disclosed by Fukuta et al. (1982) comprises two heald bars, which can reciprocate rectilinearly in the horizontal direction. The construction and the arrangement of the two heald bars are shown in Fig. 3. A detailed description of the sequences involved in achieving the shedding and picking mechanisms was given by Fukuta et al. (1982). Slight variations in the fabric structure can be obtained by slightly varying the shedding sequence, to realize either successive or alternate picking of the two sets of wefts.

Linear-linear method of dual-directional shedding

Khokar (2002b) disclosed a dual-directional shedding mechanism, called the linear-linear method of dual-directional shedding, which can be employed in a weaving device to produce a fully interlaced 3D woven fabric structure. As illustrated in Fig. 4, the linear-linear method of dual-directional shedding incorporates two mutually perpendicular heald frames, consisting of a set of heald wires with specially designed heald eyes. One heald frame reciprocates rectilinearly in the vertical direction, while the other heald frame reciprocates rectilinearly in the horizontal direction to form row-wise and column-wise sheds respectively.

Figure 4a illustrates the construction and arrangement of the heald frames, while Fig. 4b illustrates a slight modification done to the heald frames to accommodate additional non-interlacing stuffer warp yarns into the fabric structure. A small clearance is

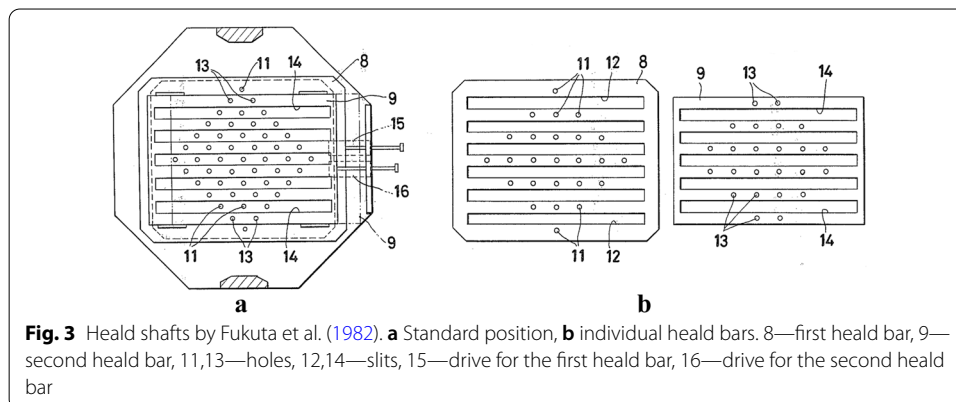

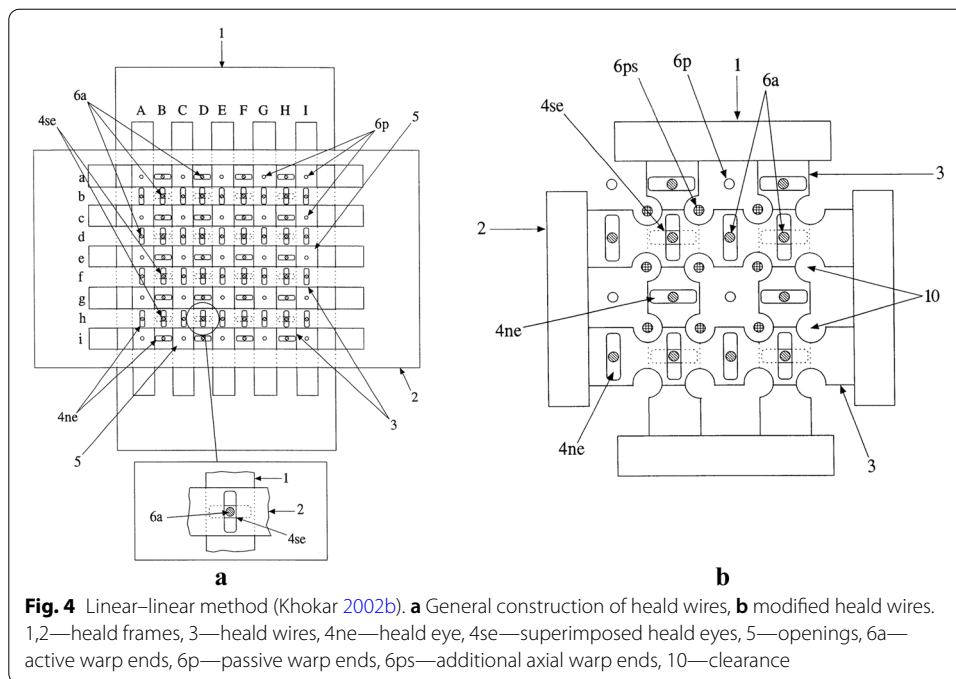

provided at the 'corners' of the superimposed heald wires of the two heald frames. Inclusion of such non-interlacing, crimp-less stuffer warp yarns is expected to improve the mechanical properties of the fabric. Figure 5 illustrates the structure of a fully interlaced 3D woven fabric produced from a 3D fully interlaced preform weaving process, which employs the linear-linear method of dual-directional shedding. A slight variation in the interlacing pattern of the 3D woven structure can be obtained by simply altering the order of shedding to realize successive picking of the wefts in the 'to and fro' directions (Fig. 5a) or alternate picking of the wefts in the 'to and fro' directions (Fig. 5b). Both these constructions have a fully interlaced network-like structure. The resulting structure has hollow pockets, which can be filled with longitudinally oriented non-interlacing additional stuffer warp yarns, by employing slightly modified heald frames as shown in Fig. 4b.

Linear-angular method of dual-directional shedding

Figure 6 illustrates the elements which are employed in effecting the linear-angular method of dual-directional shedding, which was disclosed by Khokar (2002c). The arrangement of the multi-layer warp is shown in Fig. 7. In this system, cylindrical heald shafts are used, unlike the mutually perpendicular heald frames used in the linear-linear method. These assemblies are constructed such that they can be reciprocated in two directions; along the shaft axis and about the shaft axis. These two reciprocating movements constitute the linear and the angular motions of the healds respectively, to form the sheds in the width and thickness directions of the fabric, hence the name linear-angular method of dual-directional shedding.

A fully interlaced (plain-weave) 3D woven fabric as shown in Fig. 8 can be obtained through the alternate column-wise and row-wise shed formation and the corresponding

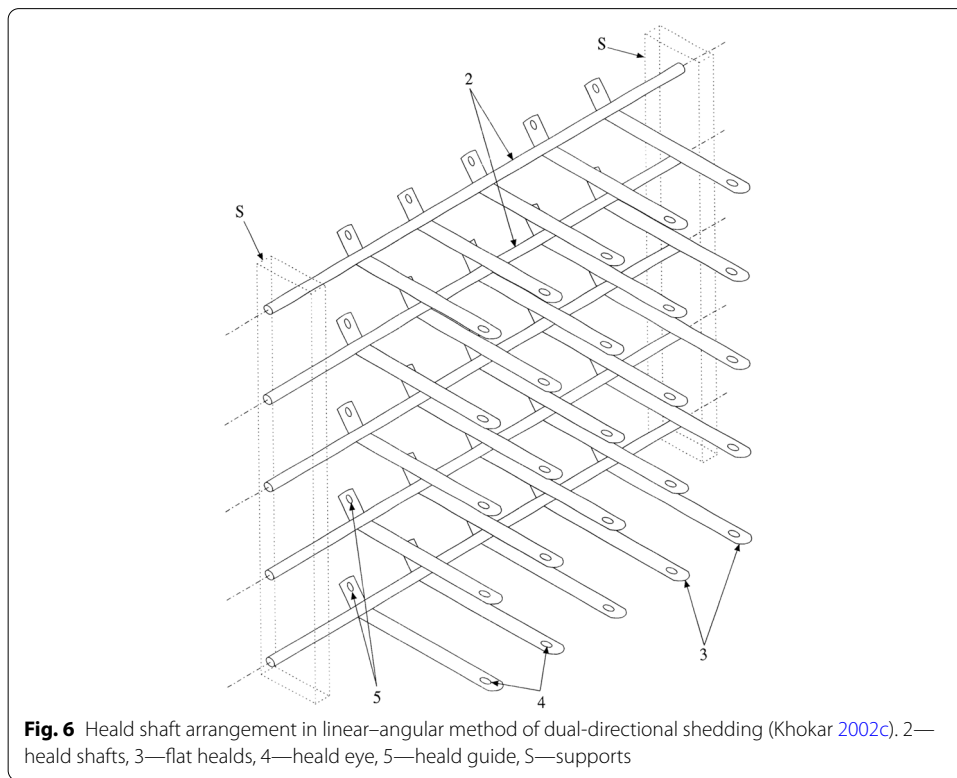
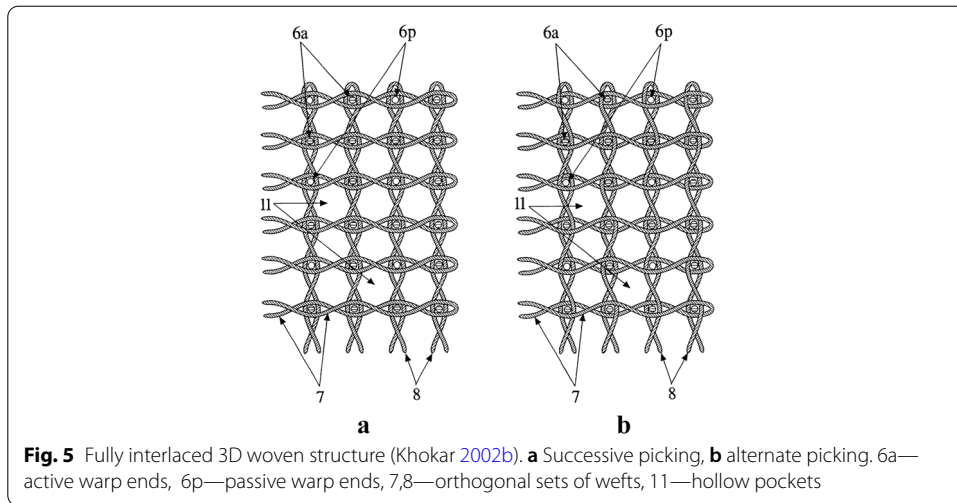

weft insertion. Similar to the linear–linear method, slight variations in the fabric construction can be obtained by changing the order of shedding so that the wefts of a given set occur successively or alternatively. Furthermore, non-interlacing stuffer yarns can be integrated into the fabric structure in the fabric-width, thickness and the two diagonal directions, by slightly changing the shedding and picking order.

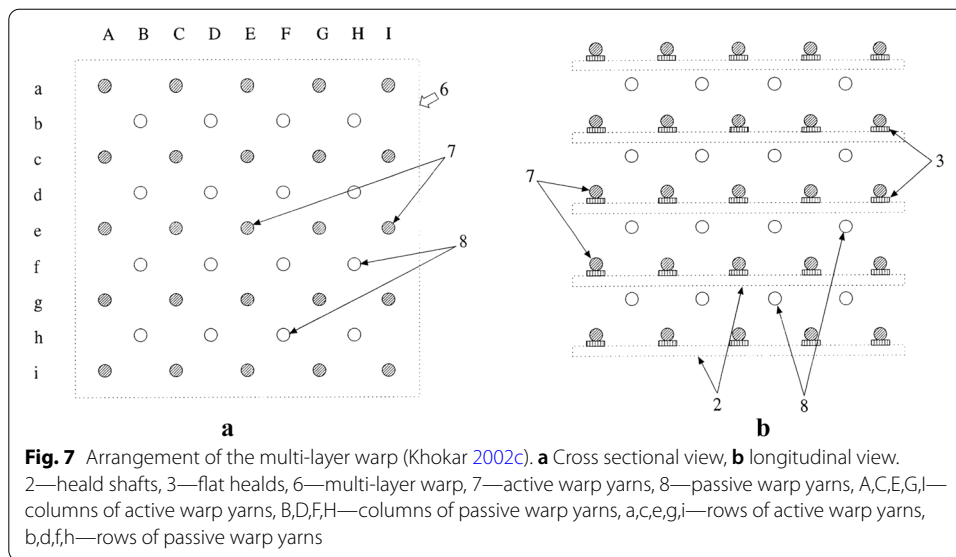

Rotating disk shedding mechanism

A recent invention describes a newly developed dual-directional shedding mechanism, which involves an array of rotating disks (Kale 2015). The array of rotating disks is arranged horizontally on the weaving machine surface. The number of disks in the array is determined by the required width and the thickness of the fabric structure to be produced. As shown in Fig. 9a, each disk is equipped with four perpendicular guides, through which the warp ends are threaded. As shown in Fig. 9b an optional guide is provided in the middle of each disk, through which non-interlacing warp ends can be introduced to the fabric structure, if required.

Weft insertion is carried out using a set of rapiers, which carry the two orthogonal sets of weft yarns. One set of rapiers are used to insert the weft yarns across the fabric-width direction, while another set of rapiers are used to insert the weft yarns in the fabric-thickness direction. The weft threads are inserted in the gaps between the thread guides of the disks (Fig. 10a). The hairpin-like wefts are locked by a locking needle and a locking thread and a crowbar is used to hold them in position. The inserted weft is beaten up to the fell of the fabric after which, the disks in the array are rotated by 90° about their axes (Fig. 10b), to form a new shed. The rotation of the disks, changes the position of the warp threads in such a way, that the wefts inserted during the previous shed, interlace with the warp threads (Fig. 10c). The wefts are again inserted in both orthogonal directions and beaten up to the fell of the fabric (Fig. 10d). The above sequence of operations combined with the other primary and secondary motions of the weaving machine results in a highly integrated 3D woven fabric of plain weave construction.

Dual-directional shedding in circular weaving

The dual-directional shedding mechanism employed in the experimental device presented by Bilisik et al. (2014) is explained here. To produce a fully interlaced 3D woven fabric structure using the circular weaving technology, the multi-layer warp must be arranged in circular rows and radial columns as shown in Fig. 11a. First, multiple sheds are formed by the sequential movement of the warp yarns in the radial column direction

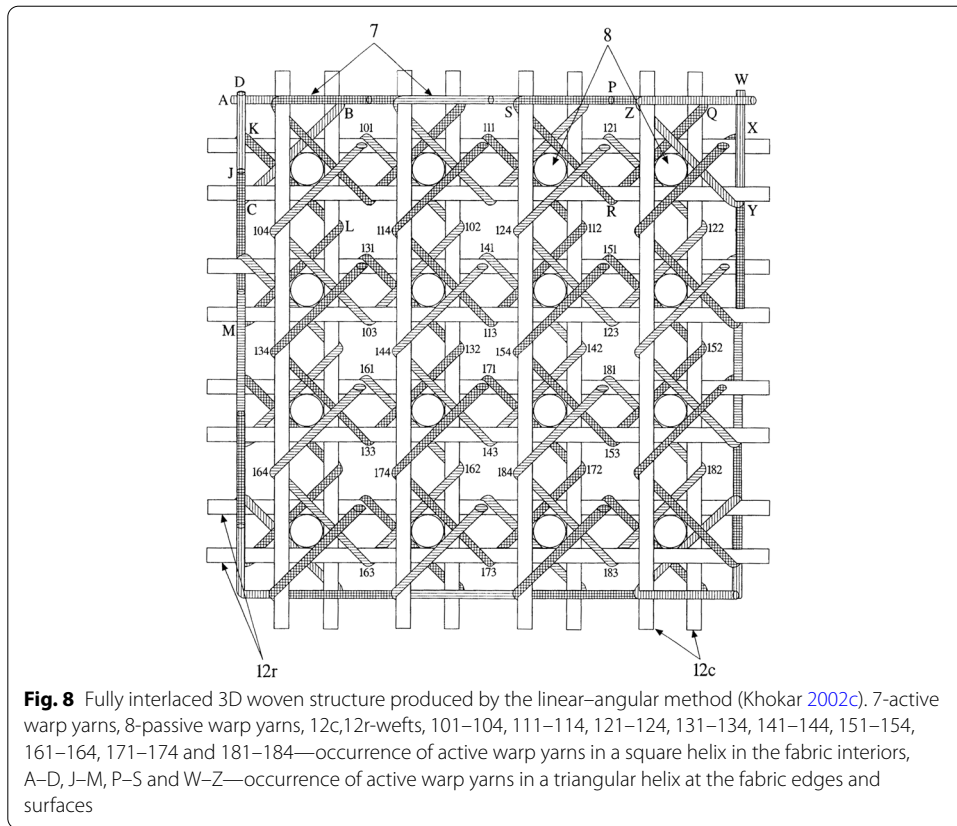

as shown in Fig. 11b. Subsequently, the circumferential weft is inserted between each layer of the multi-layer warp, in the circular row direction as shown in Fig. 11c. Next, another set of sheds are formed by the sequential movement of the warp yarns in the circular row direction as shown in Fig. 11d. Finally, the radial weft is inserted in the radial column direction and a fully interlaced circular 3D woven fabric structure is obtained as shown in Fig. 11e.

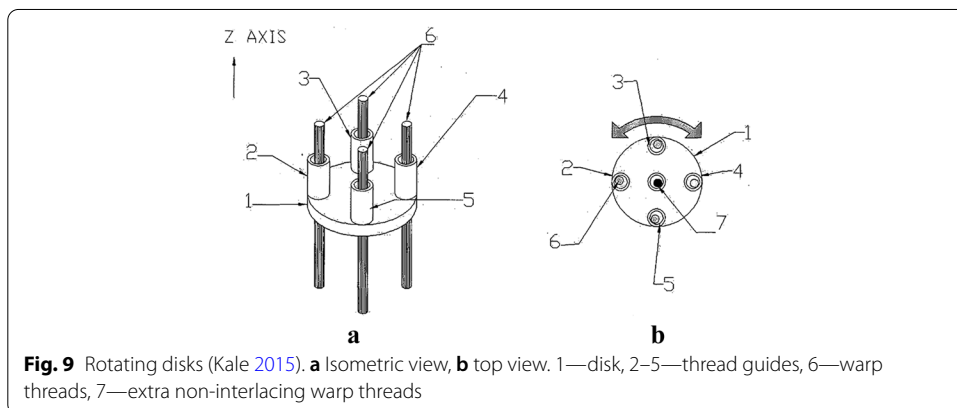

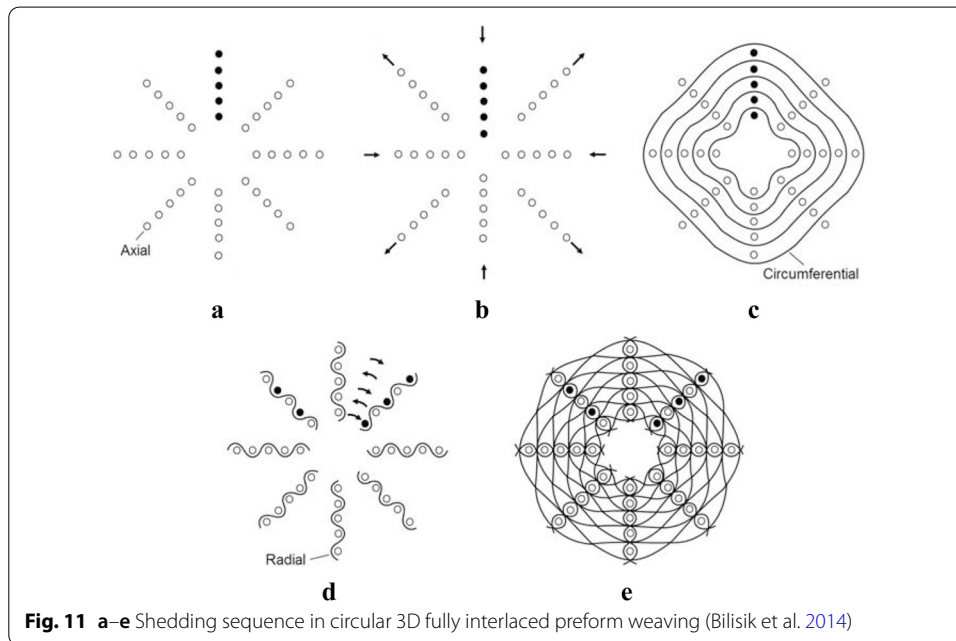
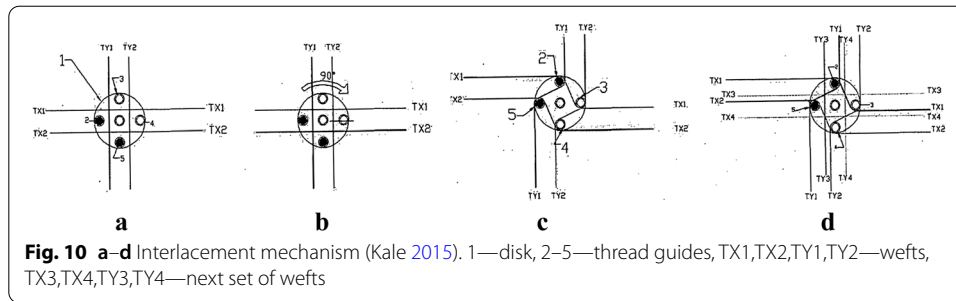

When comparing the different types of shedding mechanisms discussed above, several important differences can be identified. Due to the manner in which the heald eyes are distributed on the heald frames disclosed by Fukuta et al. (1982), the weft insertion should be carried out in the two diagonal directions of the heald frames. In contrast, the linear–linear (Khokar 2002b) and linear–angular (Khokar 2002c) methods of dual-directional shedding as well as the rotating disk shedding mechanism (Kale 2015), require the weft insertion to be carried out horizontally and vertically. The dual-directional shedding mechanism used in circular weaving, disclosed by Bilisik et al. (2014), requires the weft insertion to be carried out in the circumferential and radial directions. However, it should be noted that in 3D fully interlaced preform weaving, despite the direction of weft insertion, it must be carried out in such a way that the weft carrier is positively guided across the multiple sheds, as each weft carrier should precisely move in a linear path inside the corresponding column or row of the multi-layer warp, without disturbing the neighboring weft carriers. Furthermore, the linear–linear, linear–angular and rotating disk methods of dual-directional shedding enable the incorporation of additional non-interlacing stuffer warp ends in the longitudinal direction and it is not possible with the construction of the heald frames disclosed by Fukuta et al. (1982). It will be further

clarified in a later section of this paper, that the inclusion of non-interlacing stuffer warp yarns is important for improving the mechanical properties of the resultant 3D woven fabric structure. The rotating disk shedding mechanism offers the advantage of carrying out the weft insertion in both orthogonal directions in one shed formation, compared to the other methods of dual-directional shedding and this enhances the efficiency of the weaving process. Furthermore, the rotating disk shedding mechanism enables the production of 4-end leno weaves. The dual-directional shedding mechanism employed in circular weaving is capable of producing fully interlaced circular 3D woven preforms, which is not possible using the dual-directional shedding mechanisms employed in flat weaving. The device disclosed by Fukuta et al. (1986) is capable of producing preforms with circular cross-sections, but the device does not employ any shedding mechanism, and hence it was not considered as a 3D fully interlaced preform weaving device.

Picking and beat-up mechanisms

In the existing literature, either shuttles or rapiers had been used in carrying out weft insertion in the 3D fully interlaced preform weaving devices. The 3D fully interlaced preform weaving process demands a weft insertion mechanism, which is more advanced than what is available on conventional 2D weaving machines. In case of multi-phase weaving, 2D weaving machines form multiple sheds, but in only one direction and several weft carriers are required. However, the 3D fully interlaced preform weaving devices form two sets of sheds in two directions, hence several weft carriers equal to the total number of sheds formed are required, which can move across the sheds in a highly precise manner. Several drawbacks of the shuttle weft insertion mechanism employed in the experimental device developed by Khokar (2001) can be identified. The use of shuttles as the weft carrier requires large shed openings to be formed, which develops more strain on the warp, affects the packing density of the fabric produced and it adversely affects the efficiency of the weaving process. The large shed openings create large converging angles of warp to the fell of the fabric, which creates more stress for the beat-up mechanism, leading to tension variations in the warp. The weft cannot be laid very close to the fabric fell, leading to larger weft movements during beat up, causing more abrasion between the warp and the weft. During the weft insertion, the shuttles come in contact with the warp, leading to more abrasion in the warp. Two pairs of shuttle banks are employed in the device, which contains individual shuttle boxes for each shuttle. This consumes a large space, more energy, requires the pirn winding process and generates noise and vibration. Despite these drawbacks, the shuttle weft insertion mechanism allows the direct formation of selvages without any additional process.

The inventor of the rotating disk shedding mechanism claimed that the linear-linear and the linear-angular methods of dual-directional shedding, form large sheds, to facilitate the passage of the weft carriers such as shuttles or rapiers, and identified this as a disadvantage of those shedding mechanisms (Kale 2015). However, this claim may not be completely accurate. The height of the shed formed is usually determined by the size of the weft carrier, where shuttles, due to their larger size, require larger shed openings than rapiers. The experimental 3D weaving device developed by Khokar (2001), which employs the linear-linear method of dual-directional shedding, uses shuttles of specific construction as the weft carrier. However, it is also possible to use other types of weft

carriers such as rapiers, in conjunction with the linear–linear method of dual-directional shedding, as evident from Weerasinghe et al. (2017). The prototype 3D weaving device developed by Weerasinghe et al. (2017) employs rapiers as the weft carriers and the linear–linear method as the shedding mechanism and the authors claimed that the shed height is about 5 mm. The rapiers employed in this device have an outer diameter of 2 mm, which allows them to pass through the shed comfortably without abrading against the warp. The small shed opening reduces the strain on the warp, allows the warp ends to be closely packed and reduces the time required for shed formation resulting in higher efficiency. It also reduces the converging angle of the warp to the fell of the fabric, to a value as small as 2.89° (Weerasinghe et al. 2017), which consequently eases the beat-up mechanism and reduces the tension variation in the warp. The rapiers lay the weft about 16 mm towards the fabric fell away from the shedding zone (Weerasinghe et al. 2017), reducing the abrasion between the warp and the weft during beat-up.

The use of rapiers for weft insertion, instead of shuttles, in the device described by Weerasinghe et al. (2017), enables a simpler and more compact design of a 3D weaving machine, compared to the experimental device developed by Khokar (2001). This is due to the elimination of the need for shuttle banks, which take up a large amount of space. Furthermore, the ability of the prototype to insert the wefts from only one direction (i.e. horizontally) into both the column-wise and row-wise sheds has also contributed to the compact design of the prototype. Weerasinghe et al. (2017) claimed that the gravitational pull to which the vertically inserted wefts are subjected, make the dual weft insertion mechanism impractical, which led to the use of the current design. However, the experimental device developed by Khokar (2001), employs the dual weft insertion mechanism, through positively driven shuttles, powered by a pneumatic system. Despite the direction of weft insertion, positive control of the weft carriers is necessary to guide the weft carriers across the sheds in a linear path, within the limited space available. Therefore, even if shuttle picking is employed in 3D fully interlaced preform weaving, the shuttles are not ‘picked’ as it is done on conventional two-dimensional weaving machines. However, the use of rapiers instead of shuttles by Weerasinghe et al. (2017) allowed achieving a weft insertion with more precision and stability. Furthermore, the use of rapiers eliminates the need for a reed with a guiding element, reduces power consumption and eliminates the need for additional machinery (i.e. pirn winders). However, direct selvages cannot be produced unlike in the device developed by Khokar (2001) and a separate mechanism is needed to form the selvages.

The key advantage of the rotating disk shedding mechanism, over the linear–linear and linear–angular shedding mechanisms, lies in the fact that the two sets of orthogonal wefts can be inserted in one shed formation. This would significantly increase the efficiency of the weaving process, compared to the linear–linear and linear–angular shedding mechanisms, which require the insertion of the two sets of orthogonal wefts during separate stages. Furthermore, the system provides the benefits of its ability to form smaller shed heights, due to the use of rapiers for weft insertion. As shuttles are not used for weft insertion, an additional unit, which comprises of a locking thread needle, a locking thread and a crowbar, is required for producing the selvages of the fabric. However, it allows the formation of closed selvages, similar to the ones produced by shuttle weft insertion, at both the picking end and the receiving end of the fabric.

There is no mention of the beat-up mechanism employed in the experimental device disclosed by Khokar (2001) and the author claimed that at the time of development of the device, no suitable reed had been developed to be employed in the device. The experimental device disclosed by Weerasinghe et al. (2017) employs a comb-type reed. Due to the rotating motion of the shedding, warp let-off and fabric take-up mechanisms of the device as well as the insertion of wefts in two sets of sheds formed in two directions, a conventional reed cannot be used. The comb-type reed is employed as a separate beat-up unit and can be lowered into the multi-layer warp only when required, so it does not disturb the rotating elements. At weft insertion, the reed is lowered and once the rapiers are fully retracted, the reed performs a horizontal linear motion to press the newly inserted wefts to the fabric fell. Once the beating-up is completed, the reed is raised and retracted from the multi-layer warp to allow the next cycle of weft insertion.

As discussed above, the shuttle weft insertion has several limitations. To overcome these limitations, a novel weft carrier which can be used for weft insertion in 3D fully interlaced preform weaving devices was disclosed by Khokar (2005). Additionally, the weft carrier is equipped with a reed dent. Hence, the novel weft carrier is capable of performing the beat-up operation during the weft insertion, which results in improved weaving efficiency. Khokar claimed that the weft carrier can be employed in uniaxial noobing devices as well. To overcome the issues associated with the large shuttle height, the novel weft carrier was made thinner and wider, so that it was compact and could carry a relatively large amount of yarn. This had been made possible by arranging the yarn about two axes of rotation, inside a cartridge-like yarn supplying device. The yarn is arranged on a positively driven flanged belt which runs on two wheels. The novel weft carrier has several benefits over shuttles. It is less bulky than shuttles and can accommodate more yarn, making the weaving process more efficient. During withdrawal, it does not impart a twist into the yarn, unlike in the shuttles and due to the positive drive of the belt, the yarn is released with fewer tension variations. The weft carrier allows the weft to be laid close to the fell of the fabric. The yarn is protected from contamination as the cartridge-like yarn supplying device is enclosed. The shuttle has tips at the two corners, which guide the shuttle during its movement across the shed. These tips are arranged in a linear alignment and consequently, the back and forth movement of the shuttle has to be done in a rectangular path to lay the weft either in the upper/lower or right/left shed of a given warp yarn layer. This requires more space among the layers of the multi-layer warp. However, the novel weft carrier is equipped with tips that are offset oppositely about the central horizontal axis. This arrangement guides the carriers to lay the yarn in two different paths, relative to a layer of warp yarns in the multi-layer warp while traversing back and forth in the same linear path.

The conventional reed with vertically oriented dents is not effective in beating-up the vertical wefts as they can slip through the space between the dents. The reed dent attached to the weft carrier is capable of overcoming this issue (Khokar 2005). As the weft carrier moves across the shed, the reed dent attached to it pushes the wefts inserted during the previous shed formation, to the fabric fell, while laying the new weft. Therefore, the weft carrier can combine the picking and beating-up operations, which improves the weaving efficiency and reduces the number of working elements in the machine. Despite the benefits of this novel weft carrier, there could be certain limitations

associated with it. As the yarn is arranged on a belt, there could be disturbances to the smooth withdrawal of the yarn as several layers of yarn may tend to come off the surface of the belt. Furthermore, since the picking and beat-up mechanisms are combined, it may not be possible to adjust the beat-up force independently.

Warp let-off and fabric take-up mechanisms

In the device disclosed by Fukuta et al. (1982), no positive warp-let off mechanism had been included. A negative warp let-off mechanism had been used, the motion of which was generated by the fabric take-up mechanism. The warp sheet is fed neither through a beam nor from packages. Instead, warp ends of a finite length are freely hung from a support plate 2 with weights 6 attached to the lower ends of each warp yarn to hold them under tension, as shown in Fig. 1. This imposes serious limitations to the weaving device. The length of the fabric preform produced is limited, the tension on each warp end may not be equal and tension variations can occur due to the negative warp let-off that takes place. The produced fabric cannot be wound onto a roller, as in the conventional two-dimensional weaving processes. As can be seen from Fig. 1, the device employs a linear take-up system, with an opening 17, which determines the outer dimensions of the produced fabric preform.

No details can be found on the let-off mechanism of the weaving device developed by Khokar (2001), but the warp ends can be fed using a set of beams or directly from packages on a creel. A similar device was disclosed by Khokar (2014). This type of mechanism allows the warp let-off to be controlled positively and the tension of the warp ends can be kept uniform across the warp sheet. This allows the production of a preform with a more uniform distribution of density and yarn crimp. A linear fabric take-up unit is employed in the device, and to hold the leading ends of the warp yarns according to the cross-section of the fabric preform to be produced, a profile holder is integrated into the take-up unit. The mechanism used to give motion to the take-up unit is not disclosed.

In the experimental device disclosed by Weerasinghe et al. (2017), the warp ends are directly taken from packages on a creel and fed to the weaving zone. Tensioners are used to positively control the tension of each warp end. A linear take-up unit similar to the one employed in the device by Khokar (2001), is used and the warp ends are suspended by a profile holder in the take-up unit. The profile holder is fixed to a screw, through which the profile holder can be moved to take-up the produced fabric. Weerasinghe et al. (2017) proposed that, using differential take-up and let-off systems, with the use of a rack and pinion would be a better option and that it would allow the concurrent motion of the two systems. Since the shedding, warp let-off and fabric take-up units need to be rotated after every shed formation, all the cylindrical units enclosed together are connected through a casing connector, to provide the same concurrent rotational movement. This concurrent movement minimizes the possibilities of any undesirable stresses from being developed in the warp ends. However, undesirable torsional stresses may still be developed in the length of yarn between the let-off frame and the supply packages, due to the rotational movement. Furthermore, there is a possibility of tension variations in the warp ends. Wear of the bearings on which the cylindrical casings are mounted may also disturb the concurrent movement of the three casings, leading to the development of undesirable stresses in the warp ends. The novelty approach of this

prototype in terms of weft insertion has great potential for the future developments of the 3D fully interlaced preform weaving process. However, the possibility of developing this experimental prototype into a fully functional 3D weaving machine is yet to be investigated.

The use of a linear take-up system limits the length of fabric that can be produced, however, since the 3D weaving process is not used for producing large continuous lengths of fabrics unlike the conventional two-dimensional weaving process, this problem may not be highly significant. However, the linear take-up system increases the space taken up by the weaving machine, compared to a conventional take-up roll. Despite these limitations, using a linear take-up unit is necessary to maintain the consistency of the structure of the produced preform.

Analysis of the existing literature on 3D woven 3D fabric structures

Different structures and characteristics

The 3D fully interlaced preform weaving process enables the production of fully interlaced, highly integrated 3D woven 3D fabric structures, which can be used as preforms for composite applications. All the dual-directional shedding mechanisms discussed in this paper are capable of producing such a fabric structure, through the interlacement of three orthogonal sets of yarns. Slight variations of the interlaced structure can be achieved through the selection of successive picking or alternate picking of wefts in 'to and fro' directions. The shedding mechanisms disclosed by Fukuta et al. (1982), the linear-linear method (Khokar 2002b) and the rotating disk method (Kale 2015) produce similar structures with hollow pockets in the axial direction. The size of the axial hollow pockets can be varied by properly disposing of the multi-layer warp. The use of rapiers instead of shuttles, for weft insertion, allows closer packing of warp yarns, which will lead to smaller hollow pockets. The smaller the hollow pockets, the higher will be the cover factor and the greater will be the load-bearing and shock-absorbing capacity of the structure. In the case of the linear-linear and rotating disk methods, the hollow pockets can be filled with non-interlacing stuffer warp yarns to enhance the mechanical properties. However, this flexibility is not present in the shedding mechanism in the device disclosed by Fukuta et al. (1982). The linear-angular method (Khokar 2002c) also produces fully interlaced, highly integrated 3D woven 3D fabric structures, but the occurrence of the constituent yarns in the resultant structure is somewhat different. The active warp yarns may be made to occur in the fabric-length direction either in a helical configuration or additionally in the fabric-width and thickness direction by varying the shedding sequence. The active warp yarns occur in a 'triangular helix' at the edges and surfaces of the fabric and in a 'square helix' in the interiors. Consequently, no distinguishable axial hollow pockets can be seen in the structure. However, non-interlacing stuffer yarns can be incorporated in the fabric-width, thickness and diagonal directions of these structures made from the above-mentioned shedding systems. It further improves the mechanical properties of the structures. The circular 3D fully interlaced preform weaving process allows the production of 3D woven 3D fabric preforms with circular cross-sections.

In addition to the fully interlaced (plain-weave) structure, different weave patterns such as twills, satins, etc. can also be produced by reciprocating suitably threaded healds independently and selectively, using the linear-linear and linear-angular methods as

well as the method disclosed by Fukuta et al. (1982). The same is possible with the rotating disk method as well, by rotating the disks independently and selectively. In addition to the basic woven structures, all the above methods allow the production of tubular fabrics of either square or rectangular cross-section as well as solid profiles of shapes L, T, C, etc. by suitably disposing of the warp threads according to the cross-sectional shape of the profile required as well as carrying out the shedding and picking mechanisms in a suitable manner. Furthermore, core or sandwich type of fabrics can also be produced. The inventor of the rotating disk method claims that the production of 4-end leno weave is possible by rotating the disks by 180° and inserting the wefts, which is not possible on the other shedding mechanisms. In addition to the various types of 3D woven 3D fabric structures discussed above, noobed fabric structures, as well as multiple sheets of two-dimensional fabrics, can also be produced on 3D fully interlaced preform weaving devices. It should be noted that the circular 3D fully interlaced preform weaving process also allows the production of different weave patterns in addition to the plain-weave.

The 3D fully interlaced preform weaving process has several beneficial features which have led to the increased demand for the 3D woven 3D fabrics. The fully interlaced structure provides high structural integrity, through the binding of the yarns well into the structure. Consequently, it has much better stability and structural integrity compared to a noobed fabric structure. In a noobed fabric structure, binding of yarns takes place only at the surface. As a result, yarns can easily be pulled out of the structure due to which splitting up of the fabric structure may occur. Therefore, it is not possible to cut a noobed fabric structure into any desired shape, unlike a 3D woven 3D fabric structure. The main benefit of 3D fully interlaced preform weaving is its ability to produce near-net-shaped preforms (i.e. preforms with certain cross-sectional shapes). This minimizes material wastage as well as the need for additional binding. However, it should be noted that preforms of cross-sections with any desired shape cannot be manufactured.

Compared to a 3D woven 3D fabric structure, yarns in a noobed structure have insignificant or very small crimp, due to the non-interlacing nature of the yarns involved. The absence of crimp contributes to better flexural, tensile and compressive strength. However, the 3D fully interlaced preform weaving process is more flexible than the noobing process, due to its near-net-shaping ability and the mechanical properties of 3D woven 3D fabrics can be enhanced through the introduction of non-interlacing stuffer yarns into the structure.

Biteam, founded by Fredrik Winberg and Nandan Khokar, is a specialist manufacturer of 3D woven profiled materials (“Biteam—High Performance Profiled 3D Woven Reinforcements for Load-bearing Composite Material Structural Members” 2020). A variety of profiled 3D woven preforms of up to 60 × 60 mm and 3 m lengths are manufactured using carbon and other fibres, which are used in load-bearing and other composite material applications. This presents evidence for the commercial applications of 3D woven 3D fabric preforms produced from 3D fully interlaced preform weaving.

Mechanical and permeability properties

One of the main design challenges for 3D woven composites is the trade-off between the in-plane and out-of-plane mechanical properties (Chen 2015). The decrease in in-plane stiffness and tensile strength of composites made from 3D woven preforms can

be attributed to the presence of crimp in the woven structure. However, since the initial applications of the 3D multi-layer warp interlock woven fabrics did not require high in-plane stiffness or strength, the presence of crimp was insignificant. As the 3D woven preforms found broader scope in structural applications, the high out-of-plane tensile properties and fracture toughness properties were found to be beneficial.

Since the development of dual-directional shedding for 3D fully interlaced preform weaving, Stig and Hallström (2009) presented the first experimental results for a carbon fiber composite sample reinforced with a 3D woven 3D fabric preform, constructed using the 3D fully interlaced preform weaving process. In-plane and out-of-plane mechanical properties had been evaluated on flat beam specimens produced from the 3D fully interlaced preform weaving process and compared against the results for a 2×2 twill fabric 4-ply laminate and two non-crimp laminates. The test results suggested that the out-of-plane tensile strength and the shear strength are higher for the 3D woven composite compared to the other three composites. However, the exact strength values had not been determined for the out-of-plane tensile strength of the 3D woven composite, due to a limitation in the non-standardized test method used. It can be seen from the test results, that the 3D woven 3D fabric preforms have higher out-of-plane properties and lower in-plane properties compared to the traditional 2D-laminates (Stig & Hallström 2009). However, the inclusion of additional stuffer warp yarns is expected to improve the fibre volume fraction and in-plane mechanical properties.

Bilisik et al. (2013) investigated the effects of the weave pattern and the number of layers on 3D woven 3D fabric preforms. 3D woven 3D fabric preforms with plain, twill and satin weaves had been produced. Based on the results the authors claimed that the yarn-to-yarn spaces of the 3D woven 3D fabric preforms were high compared to the traditional 3D woven structures (i.e. orthogonal, through-thickness and angle interlock) in the fabric width. The weave patterns had shown a slight influence on the angles and the crimps of the yarn in the 3D woven 3D fabric preforms. Furthermore, the number of layers had slightly affected the yarn crimps and significantly affected the arc length and the length of z-yarn in the fabric thickness direction. The authors further claimed that the 3D woven 3D fabric preforms could improve the energy absorption properties in soft ballistic applications and improve damping properties in structural applications.

Yarn crimp has a significant impact on the stiffness of textile composites (Chan & Wang 1994) and the stiffness of textile composites made from 3D woven 3D fabric reinforcements are inherently anisotropic and governed by the fiber material, density and the crimp of yarn (Stig & Hallström 2013). Three non-linear analytical models had been developed by Stig and Hallström (2013) to predict the effect of three-dimensional yarn crimp on the longitudinal Young's modulus of carbon fiber composite materials containing a 3D woven 3D fabric reinforcement. The three models assumed three different yarn path shapes; zigzag, trapezoid and helix. The predicted longitudinal stiffness values from the three analytical models had been compared with the experimental results. All the models had predicted similar behavior, where the longitudinal stiffness decreases non-linearly with increasing crimp and the trapezoid model seemed to be in very good agreement with the experimental results. However, the authors claimed that changes in strand cross-section shape have a significant influence on the predicted stiffness values from the zigzag and trapezoid models. One of the problems is that a large number of

parameters must be known or estimated beforehand, some of which may be difficult to obtain before weaving and producing the composite. However, the complexity of the structure of a 3D woven 3D fabric demands such a high number of parameters, regardless of the type of model used. The developed model would be beneficial in setting the weaving parameters during the design stage, to achieve the required level of yarn crimp so that the produced fabric has the desired stiffness properties.

Composite beams with various cross-sectional beams such as 'T' or 'I' beams are used in a variety of constructional applications. Currently, these beams are produced by bending or folding fabric sheets as per the required cross-section, to create webs and flanges and joining them as required. For example, a 'T' beam can be produced by attaching a laminate called a 'web,' perpendicular to another laminate called a 'skin' by splitting the web into two equally thick flanges forming a double-sided 'L' and attaching the two flanges to the skin (Ekermann & Hallström 2019). This creates a cavity at the root of the web, between the web, the flanges and the skin and due to the absence of through-thickness reinforcement, this junction is susceptible to delamination. The current practice is to fill this cavity with a 'fillet' material and in the aerospace industry, a unidirectional prepreg lamina is used. Ekermann and Hallström (2019) presented a study which investigates the suitability of 3D woven 3D fabric preforms to be used as a fillet material. The response of carbon fiber reinforced polymer T-joints with 3D woven 3D fabric reinforced fillets as well as conventional unidirectional fillets, to pull-off tests had been studied. The results indicate that the T-joints with unidirectional fillets have higher failure loads than the 3D fillets, however, the spread of the strength values is less for the 3D fillets compared to the unidirectional fillets. This enables the use of lower safety margins for T-joints with 3D fillets, than what is practiced currently. However, the positive effects of using 3D fillets in T-joints should be further investigated.

To overcome the drawbacks of the composite beams with different cross-sections formed under the current practice, a novel add-on weaving method had been introduced by Khokar (2016). This method allows the production of preforms for such beams, with through-thickness reinforcement at the joints, which improves the delamination resistance. Since this method is out of the scope of this paper, the reader is referred to the literature for further reading (Kazemahvazi et al. 2016; Khokar 2016; Khokar et al. 2019). Furthermore, it should be noted that, as discussed previously, 3D fully interlaced preform weaving is capable of producing preforms of various cross-sections in a single process. Hence, it should be useful to investigate the properties of such preforms to assess their suitability to replace the current manufacturing methods for producing composite beams with different cross-sections.

In the context of 3D woven composites, permeability is a key parameter that affects the time required for the resin to impregnate the 3D woven reinforcement (Stig et al. 2015). Research had been carried out to investigate the permeability properties of various 2D and 3D woven fabric structures (Endruweit & Long 2010; Parnas et al. 1995; Pearce et al. 1998; Xiao et al. 2011). However, Stig et al. (2015) claimed that no prior research had been done to study the permeability of 3D woven 3D fabrics produced using 3D fully interlaced preform weaving. Furthermore, the authors presented an experimental study to investigate the effect of different textile parameters on the longitudinal permeability of such fabric preforms, using the unsaturated parallel flow method. Based on the

results, the authors claimed that there is no significant influence on permeability by the fraction of surface layers or the warp crimp of the preforms. Furthermore, the fiber volume fraction had indicated a significant effect on the permeability, as higher fiber volume fraction results in less permeability, due to reduced inter-yarn porosity. The method of increasing or decreasing the fiber volume fraction also strongly relates to permeability characteristics. For example, uniform transverse compaction of the preform had a more significant influence on the permeability than the influence of adding stuffer warp yarns or using coarser weft yarns in the structure. The results of the study are useful for the reader to gain some insight into the permeability characteristics of 3D woven 3D fabric preforms. However, the authors claimed that the number of specimens tested is small and not consistent for all preform samples, due to shortages of material supply. Hence, the statistical significance of the results had not been established.

A Computational Fluid Dynamics (CFD) model had been developed to investigate the effect of the fibrous architecture and the level of detail in the CFD model on permeability predictions and to predict the effect of inter-yarn porosity and locally varying intra-yarn porosity on the permeability of 3D woven 3D fabric preforms (Tahir et al. 2015). The results had indicated that the inter-yarn porosity has a significant influence on the permeability, while the effect of intra-yarn porosity is insignificant. Therefore, an accurate representation of geometrical features in the space between yarns is highly important. Furthermore, from the results, it can be seen that the overall permeability is anisotropic, but as the inter-yarn porosity increases, the permeability becomes more isotropic. The authors of the study claimed that the results from the numerical simulation are in good agreement with the experimental results of Stig et al. (2015). The model would be beneficial in establishing a trade-off between the resin impregnation time and the amount of stuffer warp yarns to be used to improve in-plane properties.

Modelling of 3D woven 3D fabric structures

Advanced modelling of composite materials is important when determining the mechanical properties of these composites, to gain acceptance for a particular application (Stig & Hallström 2012b). To analyze and predict the mechanical and permeability behavior of 3D woven 3D fabrics, used as reinforcements in composites, it is desirable to have a geometric representation of the structure, the development of which has been a key issue due to the complex nature of the structure. The existing modelling techniques used for two-dimensional fabrics are not suitable for 3D woven 3D fabrics. Stig and Hallström (2012b) presented a framework to model the internal strand geometry of 3D woven 3D fabric preforms, on a mesoscale, using a finite element simulation. The strands or yarns are represented by tubes, the properties of which mimic dry yarn properties. One of the main benefits of the model is that it does not require any geometrical measurements as inputs and requires only a relatively small number of input parameters which include the weave pattern, warp and weft yarn counts, yarn crimp, fiber diameter, the average volume fraction of the strands and the dimensions of the Representative Volume Element (RVE). Validation of the developed model had been performed through the comparison of the model against Computer Tomography (CT) scanned images of a carbon fiber 3D woven 3D fabric preform and the authors claimed that excellent correlation between the model and the real sample had been established despite certain deviations. The authors

claimed that some of the deviations may be attributed to the difficulties in measuring the yarn crimp as well as the imperfections in the real structure, rather than flaws in the model. However, through a parameter study, the authors claimed that the model is fairly insensitive to the variations of the tube properties. The modelled geometry can subsequently be used for mechanical analysis or flow simulations.

In another research, Stig and Hallström (2012a) used the method described above to develop a finite element based model to predict the elastic properties of composite materials containing 3D woven 3D fabric reinforcements. Four models had been created for four different weaves and the results had been compared against the experimental results from composite samples with reinforcements of the same weaves. According to the results, Young's modulus values from the model seem to agree with the experimental values and the authors claimed that the deviation of the longitudinal stiffness values predicted by the model is about 10%, compared to a maximum of 30–40% deviations between the predicted and experimental values, reported by previous works on 3D textile reinforced composites. From the results, it is clear that the warp crimp has a significant effect on the longitudinal Young's modulus, while the effect of warp crimp on the transverse modulus, shear moduli and the Poisson's ratios is relatively small. Furthermore, the results indicate that the inclusion of stuffer warp yarns had increased the longitudinal stiffness, transverse stiffness and shear moduli. The authors claimed that the stress and strain distributions obtained from the model can further be used for damage analysis.

Stig and Hallström (2020) presented an extended framework for developing an improved model, which attempts to overcome the limitations associated with the previous models (Stig & Hallström 2012a, b), while improving the overall yarn cross-section shapes. The results had proven this approach to be more realistic and successful compared to the framework presented by Stig and Hallström (2012b). A python framework had also been developed to automate the creation of the finite element models and to generate and store information about the models, which helps to reduce the effort in processing the modelling steps and computing time (Stig 2019). For mildly crimped yarns, both the old and new models generate similarly accurate yarn shapes, while for highly crimped yarns, the new method generates smoother and more realistic shapes, which is a key benefit of the new method. The cross-section variability along a warp yarn in the new model is less than that of the old model and more closely resembles the measured values (Stig & Hallström 2020).

Koumpias et al. (2014) presented a progressive damage model to simulate the mechanical behavior and failure mechanisms of 3D woven 3D fabric preform reinforced composites. A progressive damage model comprising three modules; stress analysis, failure analysis and material property degradation had been developed. Hashin-type failure criteria had been used for the failure analysis, taking into account, all basic failure modes, considering the highly complex nature of the failure of composite materials. The progressive damage model had been validated through a comparison with the experimental results from the study done by Stig and Hallström (2009). The predicted mechanical properties indicate good out-of-plane characteristics, which can be attributed to the reinforcement in the normal direction. Damage initiation and progression of different

damage modes had also been predicted using the progressive damage model and the results were presented (Koumpias et al. 2014). The progressive damage model would be beneficial in identifying the failure modes of 3D woven 3D fabric preforms, under different loading conditions, to assess their suitability for various applications.

Discussion

In this paper, the technological advancements in 3D fully interlaced preform weaving, as well as characteristics and modelling of 3D woven 3D fabrics, have been reviewed in detail. A summary of the existing literature that has been reviewed in this study is shown in Table 1.

3D weaving is a process that allows the manufacturing of 3D woven fabrics, in which all three sets of yarns are interlaced with each other to provide a highly integrated structure. 3D fully interlaced preform weaving differs from other 3D woven fabric manufacturing methods in that it allows the formation of two sets of sheds in two orthogonal directions, which is not possible with any other weaving method. The earliest evidence of a 3D fully interlaced preform weaving device can be found in 1982, from the device introduced by Fukuta et al. (1982), while Khokar (2001) had established a clear distinction between the 3D fully interlaced preform weaving process and other 3D woven fabric manufacturing methods. Furthermore, he had proposed the term '3D woven 3D fabrics' to distinguish the fabrics produced using the 3D fully interlaced preform weaving process from other 3D woven fabrics (Khokar 2001).

As evident from the literature, 3D fully interlaced preform weaving is a versatile fabric manufacturing method, which allows the production of a wide range of 3D woven 3D fabric structures such as plain, twill and satin weave, tubular fabrics, solid profiled fabrics, core or sandwich type of fabrics, etc. The ability to incorporate weft yarns in the bias directions (i.e. diagonal directions) allows the production of multi-axis 3D woven 3D fabrics with improved mechanical properties. Furthermore, it allows the production of noobed fabric structures. In addition to 3D woven fabrics, multiple two-dimensional woven fabrics can also be produced using a 3D fully interlaced preform weaving device. One of the most important features of the 3D fully interlaced preform weaving process is its ability to produce near-net-shaped preforms, which minimizes material wastage and the need for additional binding. The z-reinforcement provides excellent mechanical properties in the through-thickness direction of the 3D woven 3D fabrics, which is not found in the other types of 3D woven fabrics. This makes them suitable candidates for various composite applications.

Possible future directions and challenges

Most of the developments in 3D fully interlaced preform weaving devices had been focused on improving the primary weaving mechanisms. Since the dual-directional shedding mechanism introduced by Fukuta et al. (1982), several other improved shedding mechanisms had been introduced (Kale 2015; Khokar 2002b, c). The rotating disk shedding mechanism had shown significant improvements over the other shedding mechanisms, especially in terms of efficiency. This shedding mechanism has great potential and further research is required to optimize its performance and to

Table 1 Summary of the existing literature reviewed in the paper

Publication	Year	Research output/invention
Fukuta et al. (1982)	1982	Introduced a method for producing a fully interlaced 3D woven fabric structure
Khokar (2001)	2001	Described the 3D fully interlaced preform weaving process in detail and presented an experimental device developed to carry out the process
Khokar (2002b)	2002	Introduced a dual-directional shedding mechanism (linear–linear method)
Khokar (2002c)	2002	Introduced a dual-directional shedding mechanism (linear–angular method)
Khokar (2005)	2005	Introduced a method and device for simultaneously inserting the weft yarns and beating them up
Stig and Hallström (2009)	2009	Analyzed the mechanical properties of a carbon fiber composite sample reinforced with a 3D woven 3D fabric preform, constructed using the 3D fully interlaced preform weaving process
Stig and Hallström (2012b)	2012	Introduced a method to model internal strand geometry of 3D woven 3D fabrics on a mesoscale
Stig and Hallström (2012a)	2012	Introduced a numerical model to predict the mechanical behavior of composites reinforced with 3D woven 3D fabric preforms
Bilisik et al. (2013)	2013	Investigated the effects of the weave pattern and the number of layers on 3D woven 3D fabric preforms
Stig and Hallström (2013)	2013	Investigated the influence of crimp-on composites reinforced with 3D woven 3D fabric preforms
Bilisik et al. (2014)	2014	Introduced fully interlaced circular 3D woven preforms produced using circular 3D fully interlaced preform weaving
Koumpias et al. (2014)	2014	Introduced a progressive damage model to simulate the mechanical behavior and predict the strength of 3D woven 3D fabric reinforced composites
Stig et al. (2015)	2015	Presented an experimental study on the influence of fiber architecture on the permeability of 3D woven 3D fabric preforms
Tahir et al. (2015)	2015	Presented a numerical study on the influence of fiber architecture on the permeability of 3D woven 3D fabric preforms
Kale (2015)	2015	Introduced a dual-directional shedding mechanism that improves the weaving efficiency (Rotating disk method)
Weerasinghe et al. (2017)	2017	Introduced an experimental device with a novel method of weft insertion that allows the weft to be inserted from only one direction
Ekermann and Hallström (2019)	2019	Presented a study on the performance of CFRP T-joints with 3D woven 3D fabric reinforced fillets
Stig and Hallström (2020)	2020	Introduced an improved framework to model the geometries of 3D woven 3D fabric preforms on a mesoscale

incorporate it in a commercial 3D fully interlaced preform weaving device. Future research on dual-directional shedding mechanisms should focus on creating smaller sheds, so that a more compact multi-layer warp sheet can be used with an increased number of warp-ends, taking up the same space. Furthermore, smaller shed heights contribute to improved efficiency. The shed height is largely influenced by the size of the weft carrier, hence the possibility of using alternative weft carriers to replace shuttles should be investigated. The weft carrier developed by Khokar (2005) is a promising solution, which is more compact and precisely controlled, compared to a shuttle. The use of rapiers as a weft carrier can be seen in the literature (Weerasinghe et al. 2017) and further reductions in the size of the rapier could prove to be beneficial. Hence, there is room for further improvements in weft carriers to reduce their size and to achieve more precisely and positively controlled continuous weft

insertion, without the need to replenish the weft yarn. The weft insertion technique introduced by Weerasinghe et al. (2017) is a promising development, which significantly reduces the size and the energy consumption of the weaving device, but further research is required to investigate the possibility of incorporating it in a commercial 3D fully interlaced preform weaving device. The effects of rotating the shedding, warp let-off and fabric take-up units on the warp sheet should be further studied. The reed dent introduced by Khokar (2005) provides an efficient way of performing the beat-up mechanism. Further improvements may be directed towards positively controlling the beat-up force to achieve the desired level of pick density.

The existing research had not been focused on developing the secondary weaving mechanisms (i.e. warp let-off and fabric take-up). In most of the existing devices, negative warp let-off is carried out, which does not allow the tension of the warp ends to be precisely controlled. Tension variations may occur in the warp ends and it may lead to uneven crimp and density distribution in the fabric structure as well as an improper fabric formation. Hence, future research should be directed towards implementing positive warp let-off mechanisms. The fabric take-up mechanism should be properly synchronized with the warp let-off mechanism. The linear take-up units consume more floor space and inhibit the possibility of producing compact weaving devices. Hence, further research should be done to investigate the possibility of introducing an alternative form of a take-up unit.

When considering the fabric structure, future research should be directed towards improving in-plane mechanical properties. The existing researches suggest that the introduction of stuffer warp yarns into the structure results in improved mechanical characteristics (Stig & Hallström 2012a). However, this may adversely affect the permeability of the structure, inhibiting proper impregnation of the matrix material of the composite (Stig et al. 2015). Therefore, a compromise between the mechanical characteristics and the permeability properties should be made. Most of the existing research investigated the properties of 3D woven 3D fabric preforms made out of carbon fibres. The effect of using other high-performance fibres on the in-plane and out-of-plane mechanical properties should also be investigated so that a more suitable material could be selected for a particular application. To the authors' knowledge, no evidence of any research carried out on evaluating the mechanical performance of profiled structures made using 3D fully interlaced preform weaving is available in the literature. It may be worthwhile to investigate the delamination resistance at the joints of such profiled structures, in comparison with structures produced by the add-on weaving method introduced by Khokar (2016).

Conclusion

Textile based preforms as reinforcements are becoming increasingly popular in composite applications. Developments in high-performance fiber yarns and advancements in fabric manufacturing technologies have led to the production of textile structures with high strength to weight ratio, compared to traditional reinforcement materials such as steel. 3D fully interlaced preform weaving enables the production of fully interlaced 3D woven 3D fabric preforms, which can be used as reinforcements in composite

applications that demand high out-of-plane mechanical properties. A comprehensive review of the existing 3D fully interlaced preform weaving mechanisms and devices as well as 3D woven 3D fabrics had been carried out in this study. The study has led to the following conclusions.

- Two-dimensional woven fabric reinforced laminates and 3D woven fabric preforms used in composite applications suffer from poor delamination resistance and out-of-plane mechanical properties due to the lack of through-thickness reinforcement.
- The dual-directional shedding mechanism employed in 3D fully interlaced preform weaving devices, enables the production of fully interlaced 3D woven 3D fabrics, which is not possible on conventional two-dimensional weaving machines.
- 3D woven 3D fabrics possess good delamination resistance and out-of-plane mechanical properties due to the z-reinforcement introduced by the dual-directional shedding mechanism, but exhibit poor in-plane mechanical properties.
- The in-plane mechanical characteristics can be improved through the introduction of stuffer warp yarns and bias yarns into the fabric structure, but it could adversely affect the permeability properties leading to increased resin impregnation time.
- The simulation models developed to model 3D woven 3D fabrics can aid in mechanical analysis, damage analysis, flow simulations and predicting failure modes under different loading conditions.
- The existing research had focused on improving the primary weaving mechanisms of 3D fully interlaced preform weaving devices and further research should be carried out to improve the secondary weaving mechanisms as well.

Over the years, only a few researches had been carried out in developing 3D fully interlaced preform weaving devices. The main challenges faced in developing 3D fully interlaced preform weaving devices can be identified as the difficulties in developing a compact device with improved efficiency, due to the complex mechanisms involved with such devices. However, with the advancements in automation and mechatronics, it has become possible to realize complex mechanisms with simpler machine designs and less energy consumption. Developing less versatile machines (i.e. machines specialized in producing only one or a few types of structures) could make it possible to increase production rates.

In the future, 3D woven 3D fabric structures will find increased applications in construction, ballistic, industrial, aerospace, aviation and automotive fields. Further research into 3D fully interlaced preform weaving could open new avenues for 3D woven 3D preforms in composite applications.

Abbreviations

CAD: Computer-Aided Design; UHDPE: Ultra high-density polyethylene; CFD: Computational Fluid Dynamics; RVE: Representative Volume Element; CT: Computer Tomography.

Acknowledgements

The authors acknowledge the support extended by the University of Moratuwa in publishing this research.

Authors' contributions

YSP, RMHWM and PRF contributed in preparing the manuscript. SKF and TSSJ contributed with feedback and comments. All authors read and approved the final manuscript.

Authors' Information

YSP was born in Colombo, Sri Lanka, in 1993. He received a B.Sc. (Eng.) degree in Textile and Clothing Technology from the University of Moratuwa. Currently, he is serving as a Junior Lecturer attached to the Department of Textile & Clothing Technology, Faculty of Engineering, University of Moratuwa, Sri Lanka. YSP is an Associate Member of the Institute of Engineers Sri Lanka.

RMHWM was born in Kurunegala, Sri Lanka, in 1992. He received a B.Sc. (Eng.) degree in Textile and Clothing Technology from the University of Moratuwa. Currently, he is serving as a Junior Lecturer attached to the Department of Textile & Clothing Technology, Faculty of Engineering, University of Moratuwa, Sri Lanka. RMHWM is an Associate Member of the Institute of Engineers Sri Lanka.

PRF was born in Kurunegala, Sri Lanka, in May 1990. He received a B.Sc. (Eng.) degree in Textile and Clothing Technology from the University of Moratuwa, and is reading an M.Sc. in Materials Science from the same university. Currently, he is serving as a Junior Lecturer attached to the Department of Textile & Clothing Technology, Faculty of Engineering, University of Moratuwa, Sri Lanka. PRF is an Associate Member of the Institute of Engineers Sri Lanka.

SKF was born in Colombo, Sri Lanka, in 1961. He obtained an MSc in Mechanical Engineering in 1987 and a PhD in 1992 from the Textile Institute of Ivanovo, Russia. After his doctoral studies, he joined as a Senior Lecturer in the Department of Textile and Clothing Technology and became a Professor in Weaving Technology in 2015. SKF became a Fellow of the Textile Institute (UK) in 2014 and has been serving as the Treasurer of the Textile Institute Sri Lanka Section for 3 consecutive years. He served as the Head of Department of Textile and Clothing Technology from 2006 to 2009. He has authored more than 25 journal papers, more than 30 conference papers and holder of 5 patents. He renders his service as a reviewer to many international reputed journals, including the Journal of the Textile Institute.

TSSJ was born in Matara, Sri Lanka, in November 1970. He received a B.Sc. (Eng.) degree in Electronics and Telecommunications from the University of Moratuwa, an M.Sc. in Operations Research from the same university, and a Ph.D. in Robotics and Systems Control from the Saga University, Japan, in 1996, 2003, and 2005, respectively. Currently, he is serving as a Senior Lecturer attached to the Department of Textile and Clothing Technology, Faculty of Engineering, University of Moratuwa, Sri Lanka. TSSJ became a Senior Member (SM) of IEEE and a Fellow of the Textile Institute (UK) in 2017. He is also a Chartered Engineer, a founding member of the Applied Statistics Association, Sri Lanka, and a member of the Institute of Engineers Sri Lanka. TSSJ served as the Chair of the IEEE Sri Lanka Section in 2017, and he served as the editor of the Sri Lanka Section for 2 years. He has authored more than 20 journal papers, more than 20 conference papers, and holder of 2 patents. He renders his service as a reviewer to many internationally reputed journals, including IEEE journals, Science Citation indexed journals.

Funding

Not applicable.

Availability of data and materials

Not applicable.

Competing interests

The authors declare that they have no competing interests.

Author details

¹ Lecturer, Department of Textile and Clothing Technology, Faculty of Engineering, University of Moratuwa, Moratuwa, Sri Lanka. ² Professor, Department of Textile and Clothing Technology, Faculty of Engineering, University of Moratuwa, Moratuwa, Sri Lanka. ³ Senior Lecturer, Department of Textile and Clothing Technology, Faculty of Engineering, University of Moratuwa, Moratuwa, Sri Lanka.

Received: 5 November 2020 Accepted: 21 December 2020

Published online: 05 March 2021

References

- Adovasio, J. M., Soffer, O., Illingworth, J. S., & Hyland, D. C. (2014). Perishable fiber artifacts and Paleoindians: New implications. *North American Archaeologist*, 35(4), 331–352. <https://doi.org/10.2190/NA.35.4.d>
- Ali, M., Kausar, F., Shahid, S., Zeeshan, M., Nawab, Y., Riaz, R., et al. (2019). Novel derivatives of 3D woven T-shaped composites with improved performance. *The Journal of The Textile Institute*, 110(2), 267–273. <https://doi.org/10.1080/00405000.2018.1480914>.
- Behera, B. K., & Mishra, R. (2008). 3-Dimensional weaving. *Indian Journal of Fibre & Textile Research*, 33, 274–287.
- Bilisik, A. K. (1998). Multiaxial three-dimensional (3-D) circular weaving and multiaxial 3-D circular woven preforms for composite. In Y. M. Haddad (Ed.), *Advanced multilayered and fibre-reinforced composites* (Vol. 43, pp. 477–487). Dordrecht: Springer.
- Bilisik, A. K. (2000). *Multiaxial three-dimensional (3-D) circular woven fabric* (U.S. Patent No. 6,129,122). U.S. Patent and Trademark Office.
- Bilisik, K. (1991). *Three dimensional (3D) weaving and Braiding* [Unpublished doctoral dissertation].
- Bilisik, K. (2010a). Multiaxis three-dimensional circular woven preforms—"Radial crossing weaving" and "radial in-out weaving": Preliminary investigation of feasibility of weaving and methods. *Journal of the Textile Institute*, 101(11), 967–987. <https://doi.org/10.1080/00405000903080985>.

- Bilisik, K. (2010b). Multiaxis 3D weaving: Comparison of developed two weaving methods (tube-rapier weaving versus tube-carrier weaving) and effects of bias yarn path to the preform properties. *Fibers and Polymers*, 11(1), 104–114. <https://doi.org/10.1007/s12221-010-0104-y>.
- Bilisik, K. (2012). Multiaxis three-dimensional weaving for composites: A review. *Textile Research Journal*, 82(7), 725–743. <https://doi.org/10.1177/0040517511435013>.
- Bilisik, K. (2017). Two-dimensional (2D) fabrics and three-dimensional (3D) preforms for ballistic and stabbing protection: A review. *Textile Research Journal*, 87(18), 2275–2304. <https://doi.org/10.1177/0040517516669075>.
- Bilisik, K., Karaduman, N. S., Bilisik, N. E., & Bilisik, H. E. (2013). Three-dimensional fully interlaced woven preforms for composites. *Textile Research Journal*, 83(19), 2060–2084. <https://doi.org/10.1177/0040517513487791>.
- Bilisik, K., Karaduman, N. S., Bilisik, N. E., & Bilisik, H. E. (2014). Three-dimensional circular various weave patterns in woven preform structures. *Textile Research Journal*, 84(6), 638–654. <https://doi.org/10.1177/0040517513499437>.
- Bilisik, K., & Mohamed, M. H. (2009). Multiaxis three-dimensional flat woven preform (tube rapier weaving) and circular woven preform (radial crossing weaving). *Textile Research Journal*, 79(12), 1067–1084. <https://doi.org/10.1177/0040517508099395>.
- Biteam—High performance profiled 3D woven reinforcements for load-bearing composite material structural members. Biteam.com. (2020). Retrieved October 22, 2020, from <http://biteam.com/profiled-3d-woven-reinforcements.htm>.
- Broudy, E. (1993). *The book of looms: A history of the handloom from ancient times to the present*. Providence: Brown University Press.
- Chan, W. S., & Wang, J. S. (1994). Influence of fiber waviness on the structural response of composite laminates. *Journal of Thermoplastic Composite Materials*, 7(3), 243–260. <https://doi.org/10.1177/089270579400700306>.
- Chen, X. (Ed.). (2015). *Advances in 3D textiles*. Cambridge: Elsevier/WP, Woodhead Publ.
- Curiskis, J. I., Durie, A., Nicolaidis, A., & Herszberg, I. (1997). Developments in multiaxial weaving for advanced composite materials. In *Proceedings of ICCM-11, Australia* (pp. 86–96).
- Eckermann, T., & Hallström, S. (2019). Pull-off tests of CFRP T-joints with conventional and 3D reinforced fillets. *Composite Structures*, 223, 110893. <https://doi.org/10.1016/j.compstruct.2019.110893>.
- Endruweit, A., & Long, A. C. (2010). Analysis of compressibility and permeability of selected 3D woven reinforcements. *Journal of Composite Materials*, 44(24), 2833–2862. <https://doi.org/10.1177/0021998310369586>.
- Fukuta, K., Aoki, E., Nagatsuka, Y., & Kitano, T. (1986). *Method for formation of three-dimensional woven fabric and apparatus therefor* (U.S. Patent No. 4,615,256). U.S. Patent and Trademark Office.
- Fukuta, K., Onooka, R., Aoki, E., & Tsumuraya, S. (1982). *Three-dimensionally latticed flexible-structure composite* (U.S. Patent No. 4336296). U.S. Patent and Trademark Office.
- Hearle, J. W. S. (2001). *High-performance fibres*. Boca Raton: CRC Press, Woodhead Publ.
- Hu, J. (2008). *3-D fibrous assemblies: Properties, applications and modelling of three-dimensional textile structures*. Boca Raton: CRC Press.
- Kale, S. (2015). *Rotating disk shedding system for producing a woven 3D multilayer orthogonal interlaced fabric and its corresponding method* (WO/2015/044956). World Intellectual Property Organization.
- Kashif, M., Hamdani, S. T., Zubair, M., & Nawab, Y. (2019). Effect of interlocking pattern on short beam strength of 3D woven composites. *Journal of Composite Materials*, 53(20), 2789–2799. <https://doi.org/10.1177/0021998319839441>.
- Kazemahvazi, S., Khokar, N., Hallstrom, S., Wadley, H. N. G., & Deshpande, V. S. (2016). Confluent 3D-assembly of fibrous structures. *Composites Science and Technology*, 127, 95–105. <https://doi.org/10.1016/j.compscitech.2016.02.034>.
- Khokar, N. (1996). 3D fabric-forming processes: Distinguishing between 2D-weaving, 3D-weaving and an unspecified non-interlacing process. *Journal of the Textile Institute*, 87(1), 97–106. <https://doi.org/10.1080/00405009608659059>.
- Khokar, N. (2001). 3D-weaving: Theory and practice. *Journal of the Textile Institute*, 92(2), 193–207. <https://doi.org/10.1080/00405000108659570>.
- Khokar, N. (2002a). Noobing: A nonwoven 3D fabric-forming process explained. *Journal of the Textile Institute*, 93(1), 52–74. <https://doi.org/10.1080/00405000208630552>.
- Khokar, N. (2002b). *Woven 3D fabric material* (U.S. Patent No. 6,338,367). U.S. Patent and Trademark Office.
- Khokar, N. (2002c). *Network-like woven 3D fabric material* (U.S. Patent No. 6,431,222). U.S. Patent and Trademark Office.
- Khokar, N. (2005). *Method and means for textile manufacture* (U.S. Patent No. 6,889,720). U.S. Patent and Trademark Office.
- Khokar, N. (2014). *Development of innovative 2D and 3D fabric-forming processes for manufacturing reinforcements for composite materials*. In *Proceedings of the 8th Aachen-Dresden International Textile Conference, Germany*.
- Khokar, N. (2016). *Method and means for weaving, 3D fabric items thereof and their use* (U.S. Patent No. 20160201234A1). U.S. Patent and Trademark Office.
- Khokar, N., Hallström, S., & Winberg, F. (2019). Increasing energy absorption and reliability of beams by improved architecture and web-flange junctions. *Key Engineering Materials*, 812, 114–119. <https://doi.org/10.4028/www.scientific.net/KEM.812.114>.
- Koumpias, A. S., Tserpes, K. I., & Pantelakis, S. (2014). Progressive damage modelling of 3D fully interlaced woven composite materials: Progressive damage modelling of 3D woven fabrics. *Fatigue & Fracture of Engineering Materials & Structures*, 37(7), 696–706. <https://doi.org/10.1111/ffe.12142>.
- Kramrisch, S. (1968). *Unknown India: Ritual art in tribe and village*. Philadelphia Museum of Art.
- Mouritz, A. P. (2008). Tensile fatigue properties of 3D composites with through-thickness reinforcement. *Composites Science and Technology*, 68(12), 2503–2510. <https://doi.org/10.1016/j.compscitech.2008.05.003>.
- Mouritz, A. P., Bannister, M. K., Falzon, P. J., & Leong, K. H. (1999). Review of applications for advanced three-dimensional fibre textile composites. *Composites Part A: Applied Science and Manufacturing*, 30(12), 1445–1461. [https://doi.org/10.1016/S1359-835X\(99\)00034-2](https://doi.org/10.1016/S1359-835X(99)00034-2).
- Nawab, Y., Legrand, X., & Koncar, V. (2012). Study of changes in 3D-woven multilayer interlock fabric preforms while forming. *Journal of the Textile Institute*, 103(12), 1273–1279. <https://doi.org/10.1080/00405000.2012.676267>.
- Ogin, S. L., & Potluri, P. (2016). Textile-reinforced composite materials. *Handbook of technical textiles* (pp. 1–26). New York: Elsevier. <https://doi.org/10.1016/B978-1-78242-465-9.00001-X>.
- Parnas, R. S., Howard, J. G., Luce, T. L., & Advani, S. G. (1995). Permeability characterization. Part 1: A proposed standard reference fabric for permeability. *Polymer Composites*, 16(6), 429–445. <https://doi.org/10.1002/pc.750160602>.

- Pearce, N. R. L., Guild, F. J., & Summerscales, J. (1998). An investigation into the effects of fabric architecture on the processing and properties of fibre reinforced composites produced by resin transfer moulding. *Composites Part A: Applied Science and Manufacturing*, 29(1–2), 19–27. [https://doi.org/10.1016/S1359-835X\(97\)00028-6](https://doi.org/10.1016/S1359-835X(97)00028-6).
- Stig, F. (2019). Framework to facilitate textile composite modelling. In *Proceedings of the 2019 NAFEMS World Congress*, Canada.
- Stig, F., & Hallström, S. (2009). Assessment of the mechanical properties of a new 3D woven fibre composite material. *Composites Science and Technology*, 69(11–12), 1686–1692. <https://doi.org/10.1016/j.compscitech.2008.04.047>.
- Stig, F., & Hallström, S. (2012a). A modelling framework for composites containing 3D reinforcement. *Composite Structures*, 94(9), 2895–2901. <https://doi.org/10.1016/j.compstruct.2012.03.009>.
- Stig, F., & Hallström, S. (2012b). Spatial modelling of 3D-woven textiles. *Composite Structures*, 94(5), 1495–1502. <https://doi.org/10.1016/j.compstruct.2011.12.003>.
- Stig, F., & Hallström, S. (2013). Influence of crimp on 3D-woven fibre reinforced composites. *Composite Structures*, 95, 114–122. <https://doi.org/10.1016/j.compstruct.2012.07.022>.
- Stig, F., & Hallström, S. (2020). Extended framework for geometric modelling of textile architectures. *Composite Structures*, 244, 112239. <https://doi.org/10.1016/j.compstruct.2020.112239>.
- Stig, F., Tahir, M. W., Åkermo, M., & Hallström, S. (2015). An experimental study of the influence from fibre architecture on the permeability of 3D-woven textiles. *Journal of Reinforced Plastics and Composites*, 34(17), 1444–1453. <https://doi.org/10.1177/0731684415593351>.
- Tahir, M. W., Stig, F., Åkermo, M., & Hallström, S. (2015). A numerical study of the influence from architecture on the permeability of 3D-woven fibre reinforcement. *Composites Part A: Applied Science and Manufacturing*, 74, 18–25. <https://doi.org/10.1016/j.compositesa.2015.02.019>.
- Tong, L., Mouritz, A. P., & Bannister, M. K. (2002). *3D fibre reinforced polymer composites* (1st ed.). New York: Elsevier.
- Umair, M., Hamdani, S. T. A., Asghar, M. A., Hussain, T., Karahan, M., Nawab, Y., & Ali, M. (2018). Study of influence of interlocking patterns on the mechanical performance of 3D multilayer woven composites. *Journal of Reinforced Plastics and Composites*, 37(7), 429–440. <https://doi.org/10.1177/0731684417751059>.
- Umair, M., Hamdani, S. T. A., Nawab, Y., Asghar, M. A., & Hussain, T. (2019). Compression and recovery behavior of three-dimensional woven spacer composites. *Journal of Industrial Textiles*. <https://doi.org/10.1177/1528083719874477>.
- Umair, M., Nawab, Y., Malik, M. H., & Shaker, K. (2015). Development and characterization of three-dimensional woven-shaped preforms and their associated composites. *Journal of Reinforced Plastics and Composites*, 34(24), 2018–2028. <https://doi.org/10.1177/0731684415608958>.
- Vassiliadis, S., Kallivretaki, A., Domvoglou, D., & Provatidis, C. (2011). Mechanical analysis of woven fabrics: The State of the Art. In S. Vassiliadis (Ed.), *Advances in modern woven fabrics technology*. InTech: Rijeka. <https://doi.org/10.5772/25255>.
- Weerasinghe, S., Osara, E. V., Senarathna, K., Senarath, S., & Fernando, E. (2017). Method and apparatus to weave a fully interlaced three-dimensional textile structure. In *Proceedings of the 2017 Moratuwa engineering research conference*, Sri Lanka (pp 187–192). <https://doi.org/10.1109/MERCon.2017.7980479>.
- Xiao, X., Zeng, X., Long, A., & Endruweit, A. (2011). Modeling of through-thickness permeability for 3D woven fabrics. In *Proceedings of the 3rd world conference on 3D fabrics and their applications*, China (pp. 206–211).
- Yang, C., Kim, Y. K., Qidwai, U. A., & Wilson, A. R. (2004). Related strength properties of 3D fabrics. *Textile Research Journal*, 74(7), 634–639. <https://doi.org/10.1177/004051750407400714>.
- Zhang, D., Sun, Y., Chen, L., & Pan, N. (2013). A comparative study on low-velocity impact response of fabric composite laminates. *Materials & Design*, 50, 750–756. <https://doi.org/10.1016/j.matdes.2013.03.044>.

Publisher's Note

Springer Nature remains neutral with regard to jurisdictional claims in published maps and institutional affiliations.

Submit your manuscript to a SpringerOpen[®] journal and benefit from:

- Convenient online submission
- Rigorous peer review
- Open access: articles freely available online
- High visibility within the field
- Retaining the copyright to your article

Submit your next manuscript at ► [springeropen.com](https://www.springeropen.com)
